

# *F-Line*.PRO

Building networks. Empowering systems.



 *TierreGroup*.<sup>®</sup>



 *F-Line*<sup>®</sup>.PRO

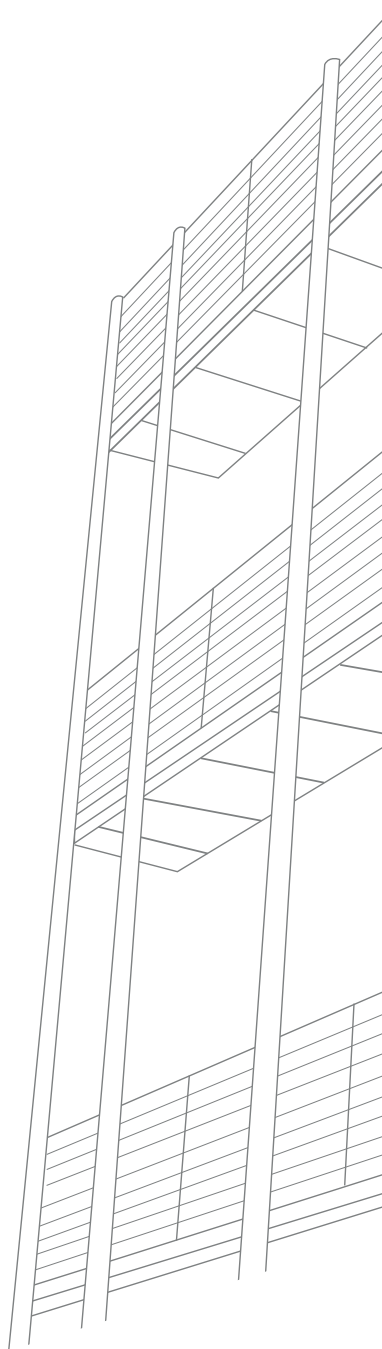

 **TierreGroup**®

 **TierreFittings**®

 **F-Line.PRO**

 **NET.Fit**®

 **INOX.Fit**®





## PLUS

Strong construction and rated up to **16 BAR**

### **LIGHTWEIGHT AND SUITABLE FOR OVERHEAD INSTALLATIONS**

Simple and fast installation time due to the **INTEGRATED PUSH-IN SYSTEM (Ø16, 20, 25 & 40)**

### **LAYOUT MODIFICATION SYSTEM (Ø20, 25 & 40)**

**VISIBLE INDICATOR WHEN FITTING NUT IS FULLY TIGHTENED (Ø20, 25, 40 & 63)**

**DOUBLE PROFILE SEALS BEFORE GRIPPING CLAW DESIGN (Ø20, 25, 40 & 63)**, to prevent tube scratches and avoid leaks

### **REINFORCED PA MATERIAL (Ø20, 25, 40 & 63)**

**PRE-INSTALLED LOCKING CLIP (Ø16)**, to prevent accidental disconnections

**STAINLESS STEEL AISI 316 DROP SYSTEM AVAILABLE** for use in aggressive environments

### **F-LINE®.PRO TEN-YEAR WARRANTY**



## RIGID TUBES



p. 32 / **FPAL-4AZ**



p. 32 / **FPAL-AZ**



p. 33 / **FPAL-GR**



p. 33 / **FPAL-VD**



p. 33 / **FPIS**

## BRACKETS



p. 34 / **FPST**



p. 34 / **FPDST**



p. 34 / **FPCL**



p. 34 / **FPCLG**



p. 35 / **FPAN**



p. 35 / **FPMT**



p. 35 / **FPMP**



p. 35 / **FPMRS**

## FLEXIBLE TUBES



p. 36 / **FPTUC**



p. 37 / **FPTUX**

## FITTINGS Ø16

Male connector  
BSPP thread



p. 39 / **FPC**

Swivel male elbow  
BSPP thread



p. 39 / **FPL**

Union connector



p. 39 / **FPUC**

Union elbow



p. 40 / **FPUL**

Union tee



p. 40 / **FPUT**

Locking clip



p. 40 / **FPLC**



## FITTINGS Ø20 - Ø25 - Ø40 - Ø63

Male BSPT  
thread connector



p. 44 / **FPC**

Male BSPT  
thread connector  
aluminum body



p. 44 / **FPCA**

Union connector



p. 44 / **FPUC**

Reduced  
union connector



p. 44 / **FPG**

Union elbow



p. 45 / **FPUL**

Union elbow 135°



p. 45 / **FPULH**

Union tee



p. 45 / **FPUT**

Reduced  
union tee



p. 45 / **FPGT**

Female tee BSPP



p. 46 / **FPGT-G**

End plug



p. 46 / **FPPE**

Quick branch



p. 46 / **FPBR**

Quick branch  
BSPP thread



p. 46 / **FPBR-G**

## WALL APPLIQUES

Single applique  
aluminum



p. 48 / **FPWLM1**

Double applique  
aluminum



p. 48 / **FPWLM2**

Female manifold  
BSPP thread stainless  
steel AISI 304



p. 49 / **FPMAN**

Brackets for FPMAN  
manifold



p. 50 / **FPSTMAN**



## STAINLESS STEEL DROP FOR AGGRESSIVE ENVIRONMENTS



p. 52 / **FPAX NEW**



p. 53 / **XVHRCPRO NEW**



p. 54 / **1410 NEW**



p. 54 / **1412 NEW**



p. 54 / **FPSAS**



p. 54 / **FPDAS**



p. 55 / **9320 NEW**



p. 56 / **EUROSTANDARD NEW SERIES**

## VALVES



p. 58 / **9210PRO**



p. 58 / **9220PRO**



p. 59 / **9120**



p. 59 / **9611**



p. 59 / **9210**



p. 59 / **9220**



p. 59 / **9250**



p. 60 / **FP1610**



p. 60 / **1110**



p. 60 / **1112**

## INSTALLATION ACCESORIES



p. 61 / **FPFD**



p. 61 / **FPCH**



p. 61 / **FPCCH**



p. 62 / **FPTT**



p. 62 / **FPUS**



p. 62 / **FPHBT**



p. 63 / **R-PTFEPRO**



p. 63 / **LOXPRO1810**



## F.R.L. UNITS

---

### 1 UNIT:

p. 64 / **FPF**p. 66 / **FPRP**p. 68 / **FPFR**p. 70 / **FPL**p. 72 / **FPFA**

### 2 UNITS:

p. 74 / **FPFR-L** **NEW**

### ACCESSORIES:

p. 76 / **FPSTRP**p. 76 / **FPSTFL**p. 76 / **FPST**

## QUICK COUPLINGS

---

p. 78 / **UNIVERSAL  
SERIES**p. 80 / **BUTTON  
SERIES  
SAFETY**p. 84 / **JAPAN  
SERIES**

## TECHNICAL & COILED TUBES

---

p. 88 / **PU-PVCPRO**p. 89 / **PVC-ACPRO**p. 90 / **FPAV**p. 92 / **UCESPRO-G**

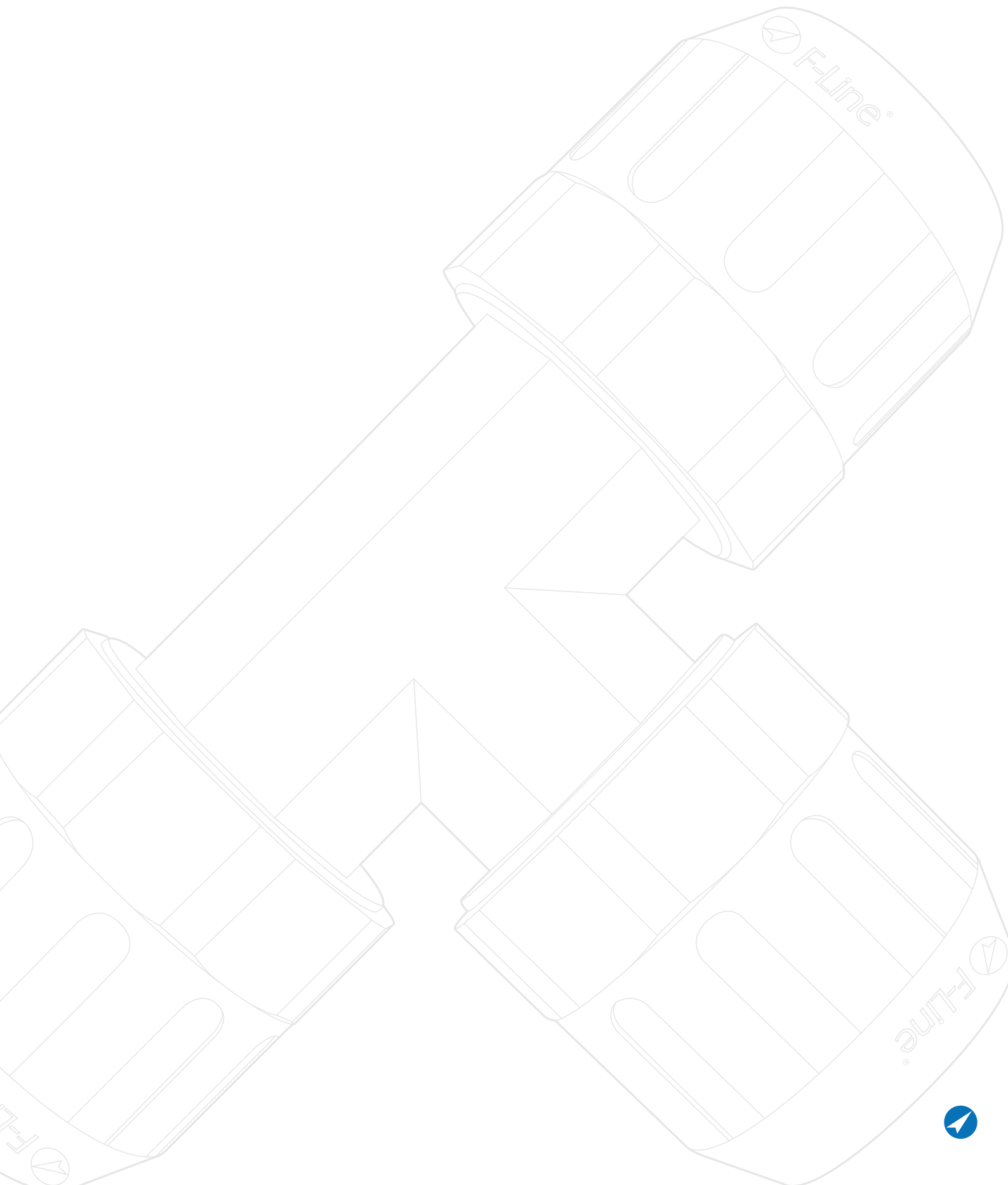

## TECHNICAL SPECIFICATIONS

The F-Line.PRO system has been designed for the realization of networks for compressed air, vacuum, neutral gases and for the construction of industrial plants. Thanks to the very long experience in the industrial field, with focus on pneumatic applications, Tierre Group created a new system, highly technological. F-Line.PRO is a quick assembly system with a perfect pneumatic seal and a remarkable mechanical endurance. The special aluminium alloy of the pipes, coated by hot electrostatic paint, and the high performance reinforced polymer used for the fittings are the best solution for compressed air networks and minimize the risk of corrosion, always granting the best possible quality of the air for a long life of the system and of the connected tools in normal working conditions. Easy to be assembled, thanks to the low weight components (tubes, fittings and accessories), connection without glue or welding needs, reusable, modular, these are only some of the advantages when choosing F-Line.PRO.

## QUOTATION SOFTWARE

The F-Line.PRO quotation software has been developed to streamline operations in every aspect. It enables users to generate a complete quotation within seconds for the system configured during the design phase, while also estimating assembly times based on a two-person installation team, an empty facility, and the availability of suitable lifting equipment.

The software allows quotations to be stored in a dedicated database, creating a complete historical archive and enabling retrieval at any time, ensuring fast and accurate operational support.

## TEN-YEAR WARRANTY

Tierre Group S.p.A. guarantees that all F-Line.PRO products are free from defects in material and workmanship, as they are made according to the guidelines of good manufacturing practices, both national and international. Unless otherwise specified by Tierre Group S.p.A., this Warranty is valid for ten years from the date of shipment of each individual product belonging to the F-Line.PRO range, provided it is used correctly and in accordance with the instructions provided or available on the F-Line.PRO website.



## PLANT DESIGN

Here below you will find some tables and technical details to be considered as suggestions for the design of an efficient network. We suggest, when possible, to create networks through a closed ring. This solution will equilibrate the flow and will work as an air storage, keeping a stable air pressure. Moreover, a closed air ring is the best solution in case of maintenance and modifications, avoiding the need of a complete stop of the system. In order to reduce shocks and vibrations, we recommend you to use FPTUC tubes (see page 36) for connecting the network to the air compressor.

### COMPRESSOR'S INDICATIVE AIR DELIVERY (AT 7 BAR)

<b>KW</b>	1,5	3	4	5,5	7,5	11	12,5	15	18	22	29	37	45	55
<b>HP</b>	2	4	6	7,5	10	15	17	20	25	30	40	50	60	75
<b>Nl/min</b>	230	400	600	900	1200	1750	2000	2500	3000	3500	4500	5500	7000	8500

### PLANT SIZING

According to the distance from the compressor to the most distant user and to the required flow, this table let you calculate the best F-Line.PRO diameter for your network, taking in consideration that the values refer to a closed ring at a pressure of 8 bar with a maximum pressure loss of 5%.

		METERS										
Nm <sup>3</sup> /h	Nl/min	25	50	100	150	200	300	400	500	1000	1500	2000
36	600	20	20	20	20	25	25	25	25	40	40	40
54	900	20	20	20	25	25	25	40	40	40	40	40
72	1200	20	25	25	25	40	40	40	40	40	40	63
105	1750	25	25	40	40	40	40	40	40	63	63	63
150	2500	25	40	40	40	40	40	40	63	63	63	63
210	3500	40	40	40	40	40	63	63	63	63	63	63
270	4500	40	40	40	40	63	63	63	63	63	63	
360	6000	40	40	40	63	63	63	63	63			
510	8500	40	40	63	63	63	63	63	63			
720	12000	40	63	63	63	63						
900	15000	63	63	63	63							
1080	18000	63	63	63								
1260	21000	63	63	63								
1560	26000	63	63									
1860	31000	63	63									
1980	33000	63										
2640	44000	63										



**FLOW DROPS FITTINGS TABLE**

This table is another useful help in order to get a right plant dimensioning. Each fitting determines a loss of charge and the table indicates the correspondence to pipe meters for every assembled fitting. The equivalent length obtained from all fittings will be added to the average length of the installed pipe.

SIZES	FITTINGS						
	FPC FPCA	FPUC	FPUL	FPUT	FPGT	FPBR	FPWLM
20	0,2	0,2	1,2	0,2	-	-	-
25	0,2	0,2	2	0,3	1,8	2	4
40	0,3	0,3	3,6	0,4	3,5	4	-
63	0,4	0,5	5	0,5	-	7	-



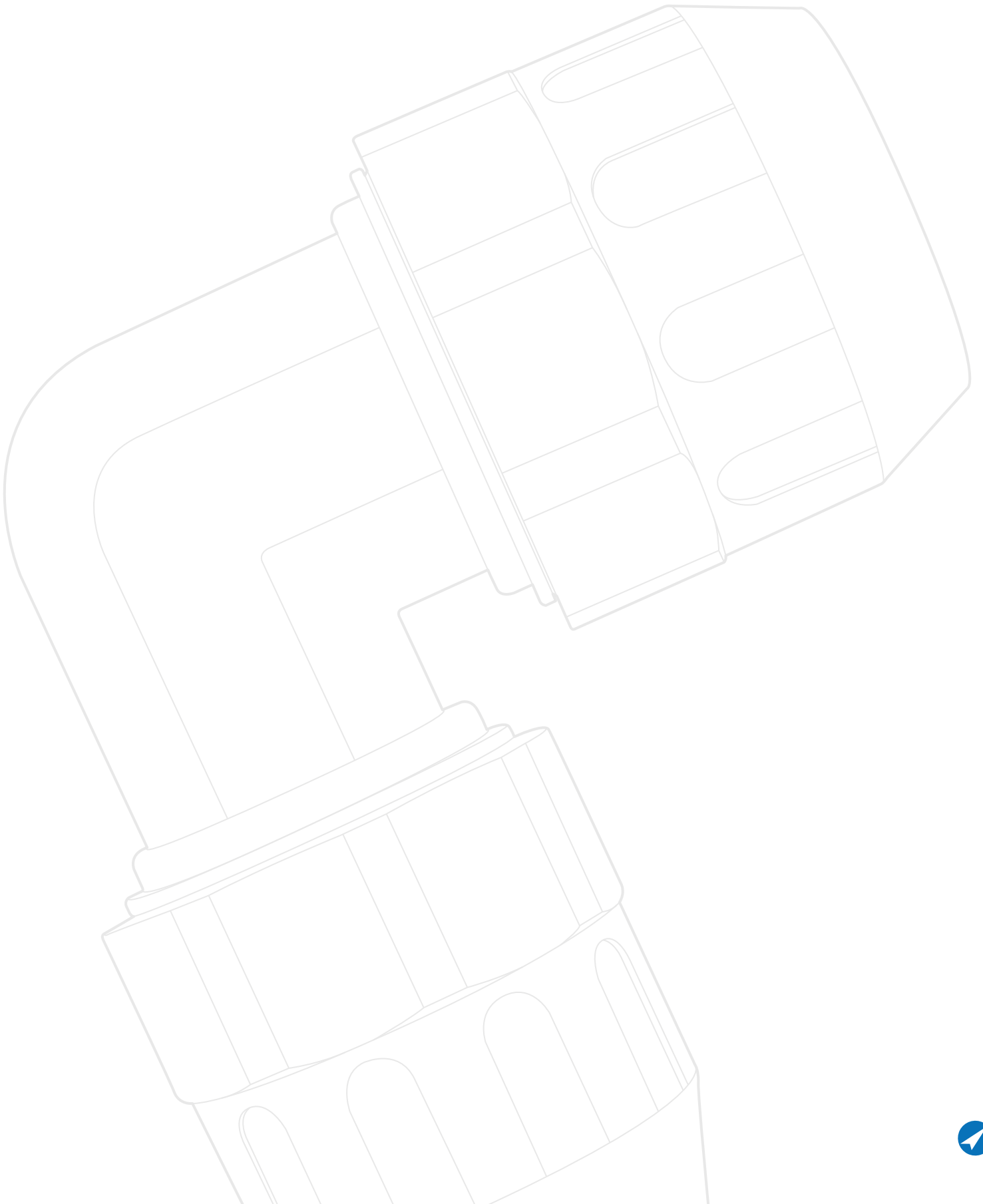

## THERMAL EXPANSIONS

It's important to check the dimensional changes due to temperature variations in order to avoid that the expansional contraction effects may cause heavy damages to the plant; for that reason it's necessary to sustain and bracket the plant in order to let the pipeline free slide between two fixed points or otherwise to insert a compensator between two fixed points if they are positioned at a distance which may cause sensible contractions/expansions.

For the system F-Line.PRO with aluminum tube this coefficient "d" is equal to 0,023 mm/m/°C.

Aluminum thermal expansion factor: 0,023 mm/m/°C

### CONTRACTION - EXPANSION OF ALUMINUM TUBE

L (m)	T MIN	T MAX	ΔT	ΔL
10	5°C	45°C	40	9,2 mm
20	5°C	45°C	40	18,4 mm
30	5°C	45°C	40	27,6 mm
50	5°C	45°C	40	46 mm
100	5°C	45°C	40	92 mm

Table of contraction - expansion depending on the length **L** of a straight stretch and the temperature difference **ΔT**.

The design and the construction of any plant will consider this phenomenon which is calculated with the following formula:

$$\Delta L = d \times L \times \Delta T$$

LEGEND:

**d**= coefficient of lateral expansion

**L**= length of piping

**ΔT**= difference of temperature in centigrade

**ΔL**= difference of length (expansion or contraction)

example: temperature is +10°C; length of piping 20m; working temperature 35°C

$$\Delta T = 35 - 10 = 25^\circ \text{C}$$

$$\Delta L = 0,023 \times 20 \times 25 = 11,5 \text{ mm}$$



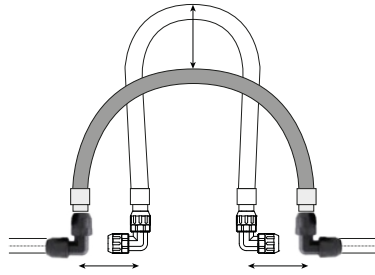

DN	FLEXIBLE TUBE LENGTH
25	1 m / 2 m
40	1,5 m / 3 m
63	1,5 m / 3 m

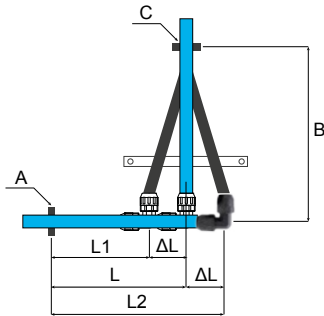

- L:** pipeline length at the installation
- L1:** length with minimum temperature
- L2:** length with maximum temperature
- ΔL:** length difference due to  $\Delta T$
- B:** length of the arms of the Lira or of the direction change
- A:** Sliding bracketing
- C:** Fixed bracketing

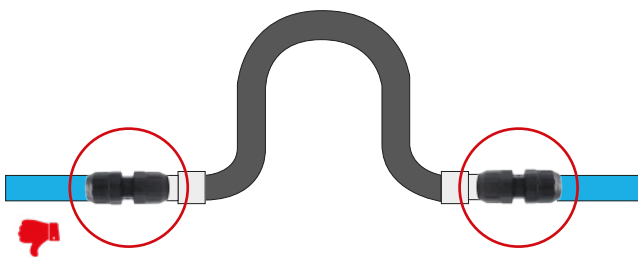

Avoid anchoring the expansion joint to two connections aligned to the same plan.

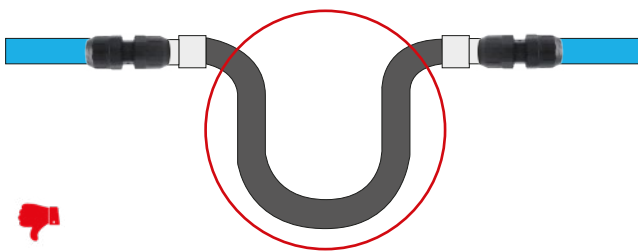

Always install the expansion joint facing upwards and not downwards in order to avoid a deposit of the condensation.

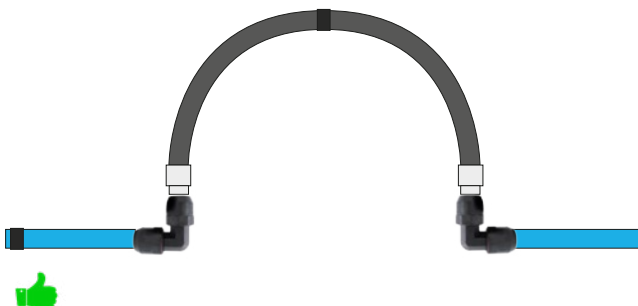

This is the correct application of the installation of expansion joint. It should be facing up and with two elbows aligned. You need also to insert two clips on the pipe aluminum fasteners close to the installation of an expansion joint.



## ASSEMBLY & DISASSEMBLY INSTRUCTIONS FOR Ø16

F-Line.PRO system has been studied and realized in order to obtain an easy, fast and safe installation.

These assembly and disassembly instructions are intended for the installer / maintainer of the F-Line.PRO system. They intend to provide a support tool for correct installation, in order to provide the best possible product performances and avoid accidents during installation and subsequent use of the system.

Any use other than the construction of a compressed air, vacuum and neutral gases networks must be considered improper and, therefore, not allowed. Improper use exempts Terre Group S.p.a. from any liability for any damage to persons or properties. Failure to comply with the conditions of use and these instructions automatically invalidates any type of warranty.

The installation, repair and maintenance operations must be carried out by suitable and qualified people and must be carried out in full compliance with the reference standards for the safety of people. The installer is responsible for everything concerning the safety of the installed products.

### ASSEMBLY INSTRUCTIONS



Always use the personal protective equipment required by the regulations. In particular, it is recommended to use protective gloves that allow a firm grip and that are able, at the same time, to prevent any injuries.

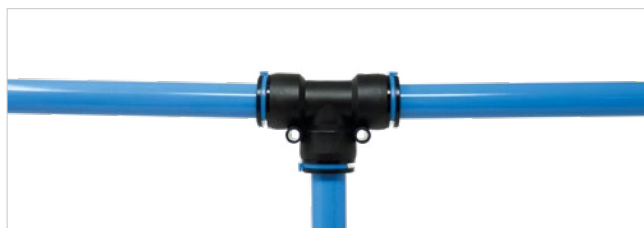

It is recommended to provide one or more drainage points for any condensation. The drainage points must be made at the lowest points of the main pipeline by using Tee fittings.



Prepare the tube for assembly. If necessary, cut the pipe using the appropriate FPTT tool. The pipe cut must be perpendicular to its axis (90 ° cut).



Always deburr the pipe, externally and internally, eliminating sharp edges, before making the connection with the fittings. Use the FPUS accessory.





By using a meter make a marking at 20mm distance from the end of the pipe in order to identify the correct and complete insertion point of the pipe into the fitting.

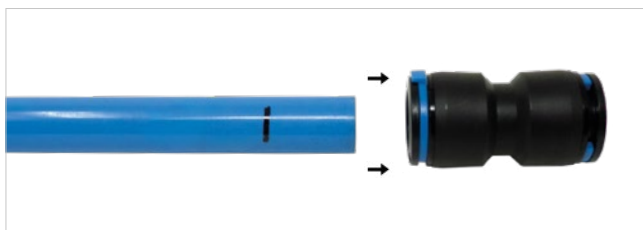

The F-Line.PRO system for 16mm diameter is push-in. Insert the pipe into the fitting WITHOUT removing the blue locking clip. Ensure that the fitting is supplied with the locking clip already installed before making the connection. If the clip is not installed, install it prior to inserting the pipe. To facilitate insertion, align the pipe with the gasket and then fully insert the pipe.



Verify the correct insertion by checking the marking previously made on the pipe with respect to the insertion of the nut (the sign must be near the end of the nut).



It is recommended to carry out a preventive test of the system or section before starting to use it.



## DISASSEMBLY INSTRUCTIONS

---

It is recommended to check that the system is off and that there is no residual pressure in before carrying out any disconnection.

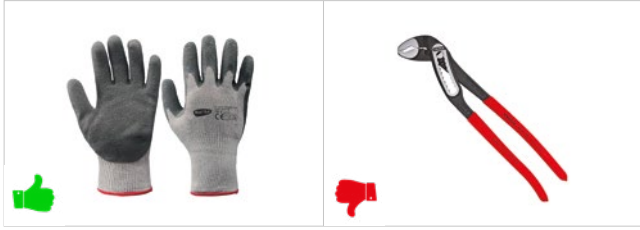

Never use unsuitable tools that could compromise or damage the fittings (eg multigrip pliers). The use of work gloves is recommended.



Remove the light blue locking clip by pulling it from the tab.



Press the black collet located at the end of the fitting and, while keeping it pressed, pull the pipe out longitudinally without tilting it inside the fitting.

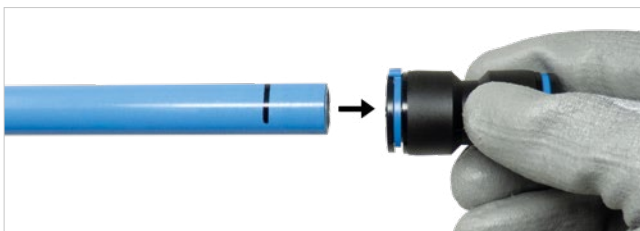

If necessary, the pipe can be reconnected to the fitting, making sure to first reposition the locking clip between the collet and the body of the fitting (see assembly instructions).





## ASSEMBLY & DISASSEMBLY INSTRUCTIONS FOR Ø20, Ø25 & Ø40

F-Line.PRO system has been studied and realized in order to obtain an easy, fast and safe installation.

These assembly and disassembly instructions are intended for the installer / maintainer of the F-Line.PRO system. They intend to provide a support tool for correct installation, in order to provide the best possible product performances and avoid accidents during installation and subsequent use of the system.

Any use other than the construction of a compressed air, vacuum and neutral gases networks must be considered improper and, therefore, not allowed. Improper use exempts Tierre Group S.p.a. from any liability for any damage to persons or properties. Failure to comply with the conditions of use and these instructions automatically invalidates any type of warranty.

The installation, repair and maintenance operations must be carried out by suitable and qualified people and must be carried out in full compliance with the reference standards for the safety of people. The installer is responsible for everything concerning the safety of the installed products.

### ASSEMBLY INSTRUCTIONS



Always use the personal protective equipment required by the regulations. In particular, it is recommended to use protective gloves that allow a firm grip and that are able, at the same time, to prevent any injuries.

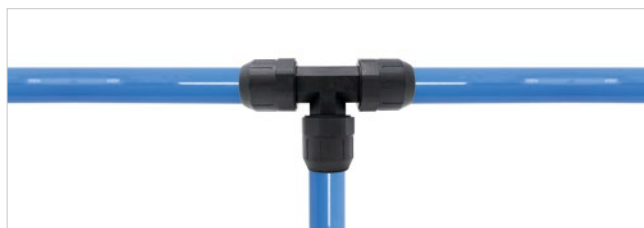

It is recommended to provide one or more drainage points for any condensation. The drainage points must be made at the lowest points of the main pipeline by using Tee fittings.

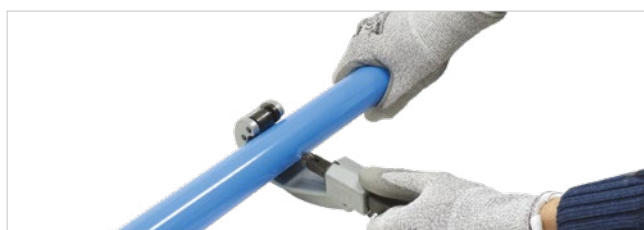

Prepare the tube for assembly. If necessary, cut the pipe using the appropriate FPTT tool. The pipe cut must be perpendicular to its axis (90 ° cut).



Always deburr the pipe, externally and internally, eliminating sharp edges, before making the connection with the fittings. Use the FPUS accessory.





Mark the pipe using the caliper located on the handle of the appropriate tightening wrench (FPCH) in order to identify the correct and complete insertion point of the pipe into the fitting.

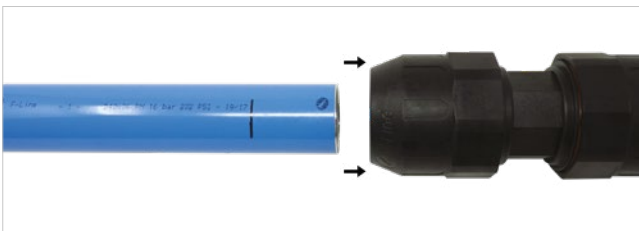

The F-Line.PRO system for diameter 20, 25 and 40 is a push-in system. Insert the pipe into the fitting WITHOUT unscrewing the nut (check that the fitting has been supplied with a completely screwed nut before connection: the screwing witness must not be visible). In order to facilitate insertion, center the tube with respect to the gasket and, subsequently, carry out the complete insertion.



Verify the correct insertion by checking the marking previously made on the pipe with respect to the insertion of the nut (the sign must be near the end of the nut).



It is recommended to carry out a preventive test of the system or section before starting to use it.



## DISASSEMBLY INSTRUCTIONS

It is recommended to check that the system is off and that there is no residual pressure in before carrying out any disconnection.



Use the dedicated FPCH keys for the unscrewing operations. Never use unsuitable tools that could compromise or damage the fittings (eg multi-grip pliers). The use of work gloves is recommended.



Unscrew the nut until the screwing witness is completely visible. Be careful not to insert the tube into the fitting during this step.

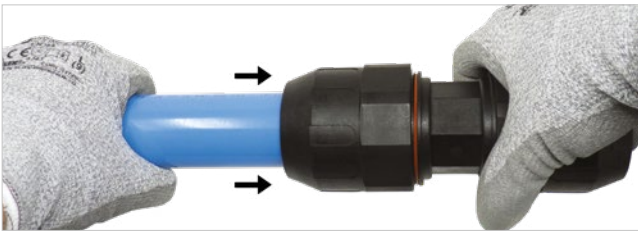

Push the tube slightly towards the fitting until the locking ring is disarmed.

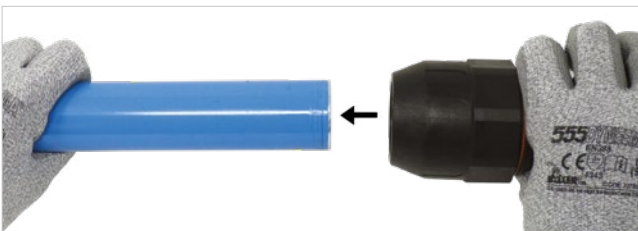

Manually remove the tube lengthwise, without tilting the tube inside the fitting.

In case of need, it is possible to re-connect the pipe to the fitting taking care to re-screw the nut in advance until the screwing witness completely disappears.



The F-Line.PRO system has been designed to make maintenance and expansion operations as easy as possible. It is possible to disconnect the pipe from the fitting simply by unscrewing the nut in the event that it is then necessary to reconnect the same pipe in the same position.

In this case, unscrew the nut being careful not to move it from its longitudinal position with respect to the pipe. The same nut can be screwed back with the tube inserted to restore the original situation.





## ASSEMBLY & DISASSEMBLY INSTRUCTIONS FOR Ø63

F-Line.PRO system has been studied and realized in order to obtain an easy, fast and safe installation.

These assembly and disassembly instructions are intended for the installer / maintainer of the F-Line.PRO system. They intend to provide a support tool for correct installation, in order to provide the best possible product performances and avoid accidents during installation and subsequent use of the system.

Any use other than the construction of a compressed air, vacuum and neutral gases networks must be considered improper and, therefore, not allowed. Improper use exempts Terre Group S.p.a. from any liability for any damage to persons or properties. Failure to comply with the conditions of use and these instructions automatically invalidates any type of warranty.

The installation, repair and maintenance operations must be carried out by suitable and qualified people and must be carried out in full compliance with the reference standards for the safety of people. The installer is responsible for everything concerning the safety of the installed products.

### ASSEMBLY INSTRUCTIONS



Always use the personal protective equipment required by the regulations. In particular, it is recommended to use protective gloves that allow a firm grip and that are able, at the same time, to prevent any injuries.



It is recommended to provide one or more drainage points for any condensation. The drainage points must be made at the lowest points of the main pipeline by using Tee fittings.

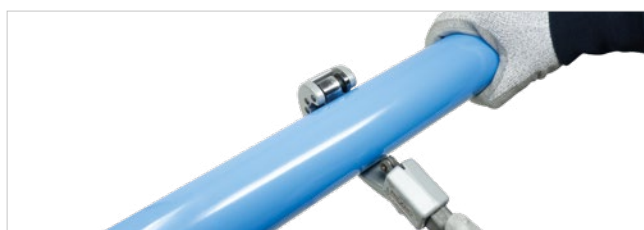

Prepare the tube for assembly. If necessary, cut the pipe using the appropriate FPTT tool. The pipe cut must be perpendicular to its axis (90 ° cut).

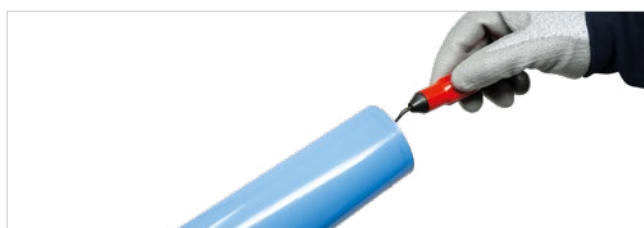

Always deburr the pipe, externally and internally, eliminating sharp edges, before making the connection with the fittings.



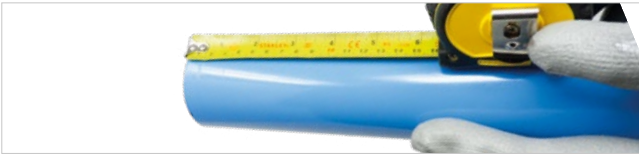

By using a meter make a marking at 90mm distance from the end of the pipe in order to identify the correct and complete insertion point of the pipe into the fitting.



Prepare the fitting by unscrewing the locknut, leaving 2–3 turns of thread so that the internal clamp can fully open.

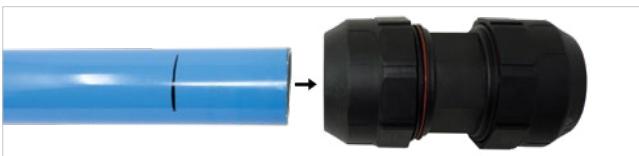

Insert the pipe into the fitting, making sure to align it with the gasket. Then, fully insert the pipe until it reaches the stop inside the fitting.



Manually tighten the fitting's locknut to prevent the pipe from slipping out during the assembly phase with wrenches.



Then, complete the tightening using the appropriate FPC and FPCCH tools, making sure the locknut covers the orange tightening indicator located on the body of the fitting.



Verify the correct insertion by checking the marking previously made on the pipe with respect to the insertion of the nut (the sign must be near the end of the nut).



It is recommended to carry out a preventive test of the system or section before starting to use it.



## DISASSEMBLY INSTRUCTIONS

It is recommended to check that the system is off and that there is no residual pressure in before carrying out any disconnection.



Use the dedicated FPCCH and FPCCH keys for the unscrewing operations. Never use unsuitable tools that could compromise or damage the fittings (eg multigrip pliers). The use of work gloves is recommended.



Unscrew the nut until the screwing witness is completely visible.

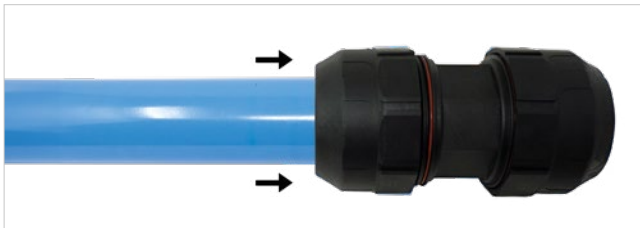

Push the tube slightly towards the fitting until the locking claw is disarmed.

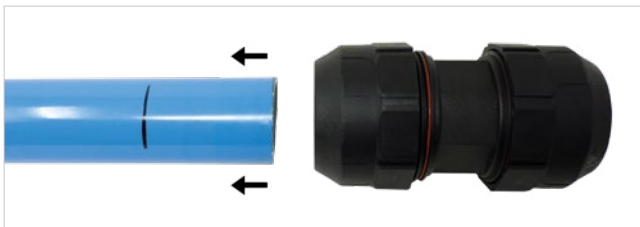

Manually remove the tube lengthwise, without tilting the tube inside the fitting.

If necessary, the pipe can be reconnected to the fitting by repeating the instructions provided on the previous page.





## ASSEMBLY INSTRUCTION - QUICK BRANCH

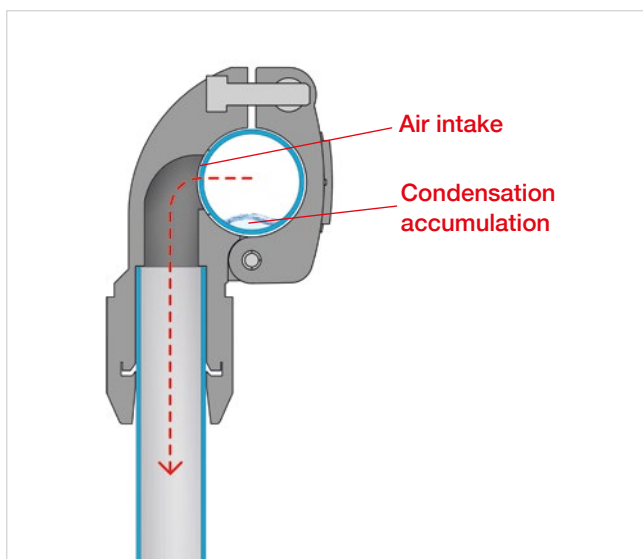

F-Line.PRO quick branches allow to get a quick branch from the main conduit without cutting the pipeline and without having the need to prepare the pipes in advance. Moreover, the air intake is positioned above the level at which the condensation accumulation could be inside the tube in order to ensure an excellent air quality.



Place the quick branch in the opposite direction of its final installation position, aligning the markings on it with the dotted line on the FPAL pipe.



By using the correct side of the centering template, corresponding to the guide on the fitting, position it at the center of the hole and use the drilling tool to make a pre-hole on the pipe.



Once the pipe is pre-drilled and the center of the hole is identified, remove the centering template and use the drilling tool to complete the drilling of the pipe, taking care not to hit the opposite side of the pipe with the tip of the mill tool.





Remove the quick branch and deburr the hole in order to avoid any residue remaining on the edges or on the surface of the pipe.



Position the mill vertically, allowing the hook to fall inside the outline of the tip and remove the residual aluminum disk.



Fix the branch so that the internal part will stay correctly in the hole. F-Line.PRO branches have a guided air intake that go inside the tube so that, once they are fixed, it will be impossible for them to move from their position. This system ensure the functioning, always guaranteeing the maximum air flow and eliminating any risk of leakages.



## BRACKETING METHOD

Please, refer to the following indications in order to make a proper bracketing system for your F-Line.PRO network. We recommend the use of F-Line.PRO wall fasteners (FPST) and the related spacers (FPDST) in order to avoid any possible trouble and in order to keep the system safe.

DN	DISTANCE IN METERS BETWEEN WALL FASTENERS DEPENDING FROM THE MAXIMUM TEMPERATURE DIFFERENCE		
mm	< 20°C	30°C	40°C
20	2,5	2	1,5
25	3	2,5	2
40	4	3,5	3
63	4	3,5	3

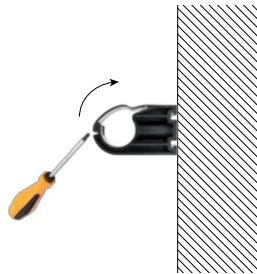

The F-Line.PRO wall fastener can be used both in horizontal or vertical position. Place the FPST at the desired height and open the hook with a screwdriver.



All wall fasteners can be installed using an M8 hexagonal nut to be inserted inside the FPST (by using a threaded bar). It's also possible to use self-tapping screws with a screw-anchor in case of installation on a wall or concrete.

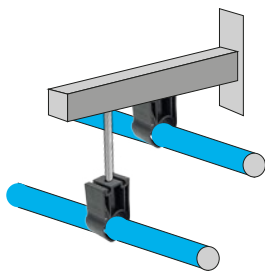

You can secure the wall fastener to any type of clamping system and then insert the tube into the wall fastener and set the hook.



Fasteners can be installed with spacers (FPDST) in order to compensate the distance from the wall.



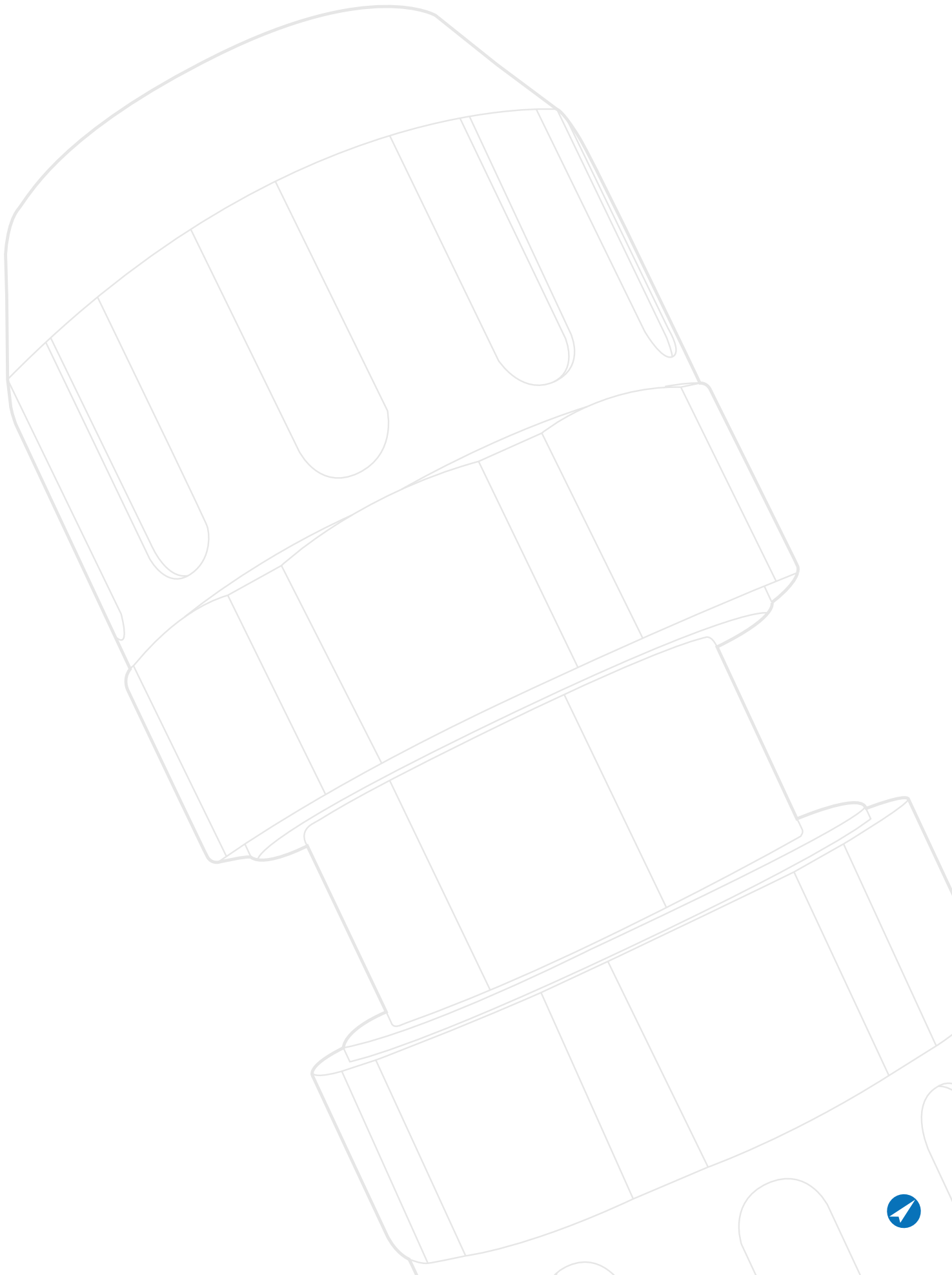



-20°C ÷ +80°C



Working pressure:

16 Bar

Negative pressure:

-0,95 Bar ( - 95 kPa)



Compressed air,  
non-aggressive gases and  
vacuum

Resistant to mechanical shocks and U.V.  
Fire resistance. Non-flammable with no  
propagation of flame.

Features a dotted line to assist with the  
correct installation of the FPBR quick  
branch.

Tube: Aluminum AN AW 6060 T6

Light blue tube: RAL 5012

Green tube: RAL 6018

Grey tube: RAL 7001



Manufactured with seamless  
extrusion.

Exterior surface painted with polyester  
powder.

## PED

SILICONE FREE



Products in compliance with  
EC Regulation 1907/2006



Products in compliance with  
the directive EU 2015/863

### FPAL-4AZ

### Aluminum pipe 4 meters light blue

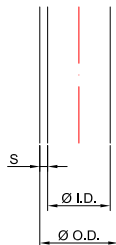

CODE	ØOD	ØID	S	WEIGHT (g/m)
FPAL1614-4AZ	16	14	1	100
FPAL2017-4AZ	20	17	1,5	200
FPAL2522-4AZ	25	22	1,5	275
FPAL4036-4AZ	40	36	2	585

### FPAL-AZ

### Aluminum pipe 5,7 meters light blue

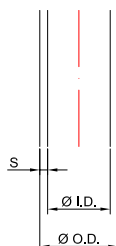

CODE	ØOD	ØID	S	WEIGHT (g/m)
FPAL2017-AZ	20	17	1,5	200
FPAL2522-AZ	25	22	1,5	275
FPAL4036-AZ	40	36	2	585
FPAL6359-AZ	63	59	2	1000



**FPAL-GR**

Aluminum pipe 5,7 meters grey

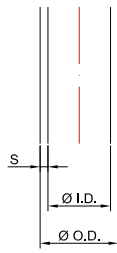

CODE	ØOD	ØID	S	WEIGHT (g/m)
FPAL2017-GR	20	17	1,5	200
FPAL2522-GR	25	22	1,5	275
FPAL4036-GR	40	36	2	585
FPAL6359-GR	63	59	2	1000

**FPAL-VD**

Aluminum pipe 5,7 meters green

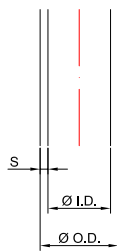

CODE	ØOD	ØID	S	WEIGHT (g/m)
FPAL2017-VD	20	17	1,5	200
FPAL2522-VD	25	22	1,5	275
FPAL4036-VD	40	36	2	585
FPAL6359-VD	63	59	2	1000

**FPIS**

Double bend light blue

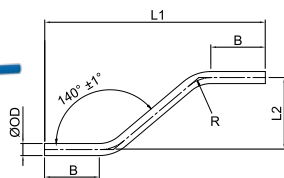

CODE	ØOD	B	R	L1	L2	WEIGHT (g)
FPIS20	20	109	60	440	150	100
FPIS25	25	113	75	460	150	140



**FPST**

## Fixing clip rigid pipe with onsert for M8 nut

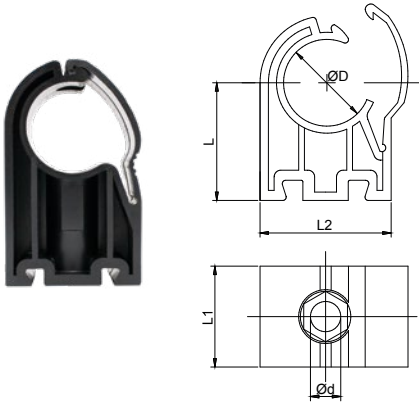

CODE	ØD	L	L1	L2	Ød	WEIGHT (g)
FPST16	16	35	30	31	9	18
FPST20	20	35	30	31	9	18
FPST25	25	35	30	38	9	20
FPST40	40	70	40	60	9	74
FPST63	63	70	40	94	9	120

M8 nut included

**FPDST**

## Spacer for fixing clip rigid pipe

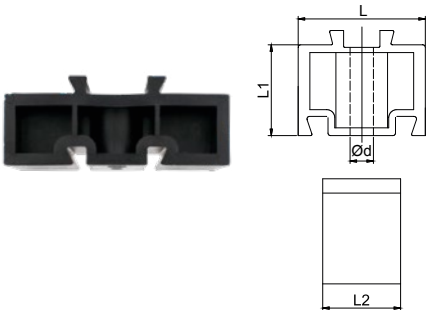

CODE	L	L1	L2	Ød	WEIGHT (g)
FPDST2032	49,0	35,0	30,0	9,0	24
FPDST4063	94,0	30,0	40,0	9,0	55

FPDST2032: to be used with FPST16, FPST20 and FPST25

FPDST4063: to be used with FPST40 and FPST63

**FPCL**

## Zinc-plated steel collar for flexible tube



CODE	Ø	THREAD	WIDTH	THICKNESS	SCREWS	WEIGHT (g)
FPCL25	35 - 44	M8 - M10	20	1,5	M6x25	62,5
FPCL40	44 - 52	M8 - M10	20	1,5	M6x25	68,5
FPCL63	74 - 82	M8 - M10	20	1,5	M6x25	-

FPCL25: to be used with FPTUC25G06, FPTUX25-1000 and FPTUX25-2000 tubes

FPCL40: to be used with FPTUC40G08, FPTUX40-1500 and FPTUX40-3000 tubes

FPCL63: to be used with FPTUC63G10, FPTUX63-1500 and FPTUX63-3000 tubes

**FPCLG**

## Zinc-plated steel collar with rubber protection for aluminum tube



CODE	Ø	THREAD	WIDTH	THICKNESS	SCREWS	WEIGHT (g)
FPCLG2025	20 - 25	M8 - M10	20	1,5	M6x25	61,5
FPCLG40	38 - 44	M8 - M10	20	1,5	M6x25	78
FPCLG63	59 - 65	M8 - M10	20	1,5	M6x25	-

FPCLG2025: to be used with FPAL2017 and FPAL2522 pipe

FPCLG40: to be used with FPAL4036 pipe

FPCLG63: to be used with FPAL6359 pipe



**FPAN**

Wall anchoring



CODE	THICKNESS	DRILL HOLE Ø X DEPTH	ANCHORING LENGHT	THREAD	WEIGHT (g)
FPAN60	10	10x50	60	M10x25	46
FPAN85	16	10x65	85	M10x40	56,6

**FPMT**

Beam clamp

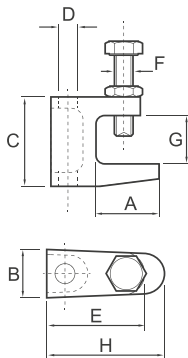

CODE	F	A	B	C	D	E	G	H	NOMINAL LOAD (N)	WEIGHT (g)
FPMTM8	M8	21	19	35	M8	35	18	38	1200	85

**FPMP**

Electrolytic zinc-plated wall bracket

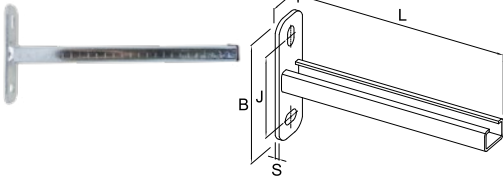

CODE	L	A	B	S	J	HOLE Ø	WEIGHT (g)
FPMP280	280	40	120	4	81,5	18x11	500

Bracket profile: 32/20x2,5 (Profile 23x11 width 35mm)  
Permissible load: 38kgf

**FPMRS**

Reinforced bracket

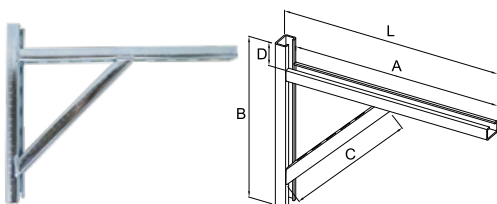

CODE	L	A	B	C	D	WEIGHT (g)
FPMRS370	370	345	275	250	40	1048
FPMRS545	545	520	380	380	46	1580

Bracket profile: 32/20x2,5 (Profile 23x11 width 35mm)  
Permissible load: 60kgf (FPMRS370)  
40kgf (FPMRS545)





-40°C ÷ +100°C  
with hydraulic, synthetic and  
petroleum-derived fluids

-40°C ÷ +70°C  
with compressed air



Working pressure:  
16 Bar



Compressed air,  
non-aggressive gases and  
vacuum



Tube: Black synthetic rubber  
reinforced with braided steel  
Thread: Carbon steel

Resistant to synthetic fluids, petroleum-  
based fluids, water-based fluids, lubricants,  
hydrocarbons, fuels etc.

## FPTUC

### Tube for compressor connection with female swivel fitting

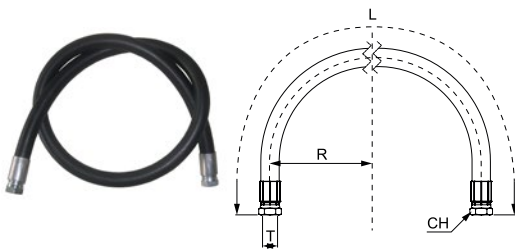

CODE	DN	ØOD	T	CH	R (BENDING RADIUS)	L (m)
FPTUC25G06	25	35,2	G 1"	42	300	0,5
FPTUC40G08	38	49,7	G 1-1/2"	55	500	1,32
FPTUC63G10	63	76,4	G 2-1/2"	85	720	2





-30°C ÷ +80°C



Working pressure:  
16 Bar  
Negative pressure:  
- 0,95 Bar ( - 95 kPa)



Compressed air,  
non-aggressive gases and  
vacuum



**Tube:** Black SBR/NBR oil mist resistant. High tensile textile cords reinforcement. Black SBR abrasion and ozone resistant cover

**Stem:** Aluminum

Smooth textile surface.

Resistant to abrasion, weather conditions and aging.

## FPTUX

## Flexible expansion joint

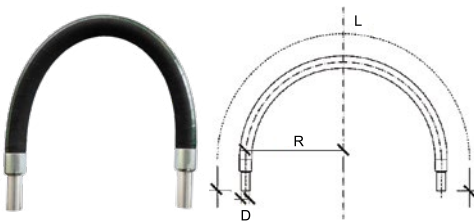

CODE	DN	ØOD	D	R (BENDING RADIUS)	L (m)
FPTUX25-1000	25	35,0	25	250	1
FPTUX25-2000	25	35,0	25	250	2
FPTUX40-1500	38	50,0	40	380	1,5
FPTUX40-3000	38	50,0	40	380	3
FPTUX63-1500	63	79,0	63	630	1,5
FPTUX63-3000	63	79,0	63	630	3



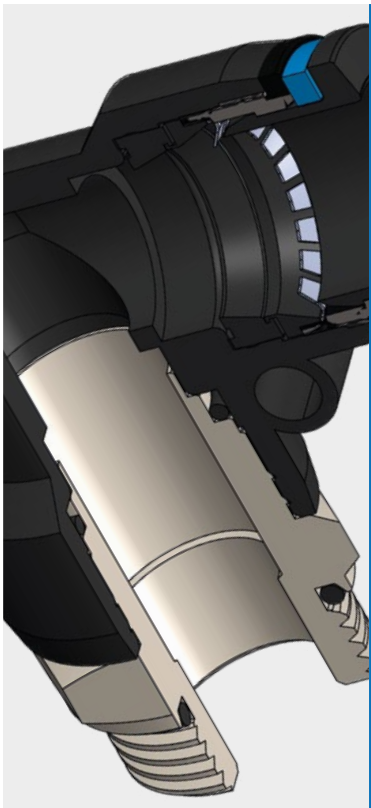

-20°C ÷ 80°C



Working pressure:

16 Bar

Negative pressure:

- 0,95 Bar ( - 95 kPa)



Compressed air & vacuum  
(do not use with water)



Parallel gas BSPP ISO 228  
G1/2"

Body: Nickel-plated brass and PBT

Collet: POM

Collar: Black anodised aluminium



Lock claw: Stainless steel AISI 301

Back ring: POM

Seal: NBR

O-ring: NBR

Locking clip: POM (light blu)

**SILICONE FREE**



Products in compliance with  
EC Regulation 1907/2006

**RoHS3**

Products in compliance with  
the directive EU 2015/863

## DETTAGLI COSTRUTTIVI

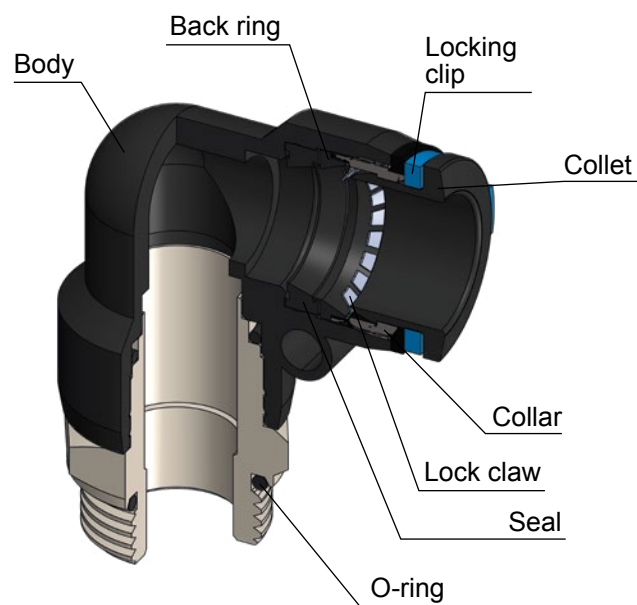

**FPC**

Male connector BSPP thread with pre-installed locking clip

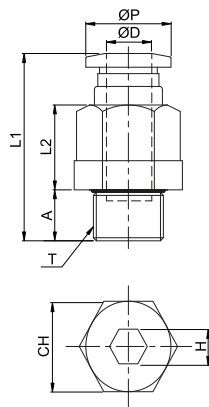

CODE	ØD	T	ØP	A	L1	L2	CH	H	WEIGHT (g)
FPC16G04	16	G 1/2"	24,3	8	36,1	18	24	10	50,7

**FPL**

Swivel male elbow BSPP thread with pre-installed locking clip

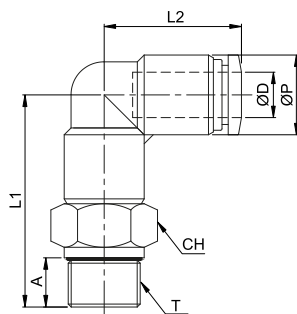

CODE	ØD	T	ØP	A	L1	L2	CH	WEIGHT (g)
FPL16G04	16	G 1/2"	26	8	42	33	24	66,5

**FPUC**

Union connector with pre-installed locking clip

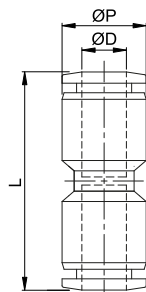

CODE	ØD	ØP	L	WEIGHT (g)
FPUC16	16	26	51	24,5



**FPUL**

## Union elbow with pre-installed locking clip

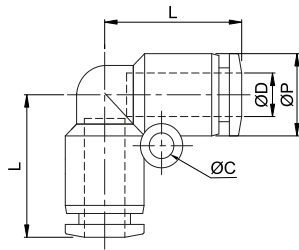

CODE	ØD	ØP	ØC	L	WEIGHT (g)
FPUL16	16	26	5,1	33	27

**FPUT**

## Union tee with pre-installed locking clip

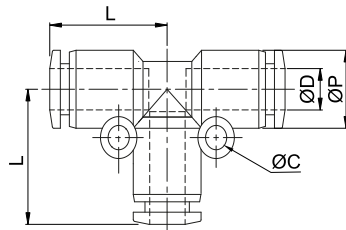

CODE	ØD	ØP	ØC	L	WEIGHT (g)
FPUT16	16	26	5,1	33	39,7

**FPLC**

## Locking clip

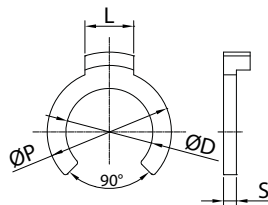

CODE	Ø	ØD	ØP	L	S
FPLC16	16	18,3	24,5	6	2



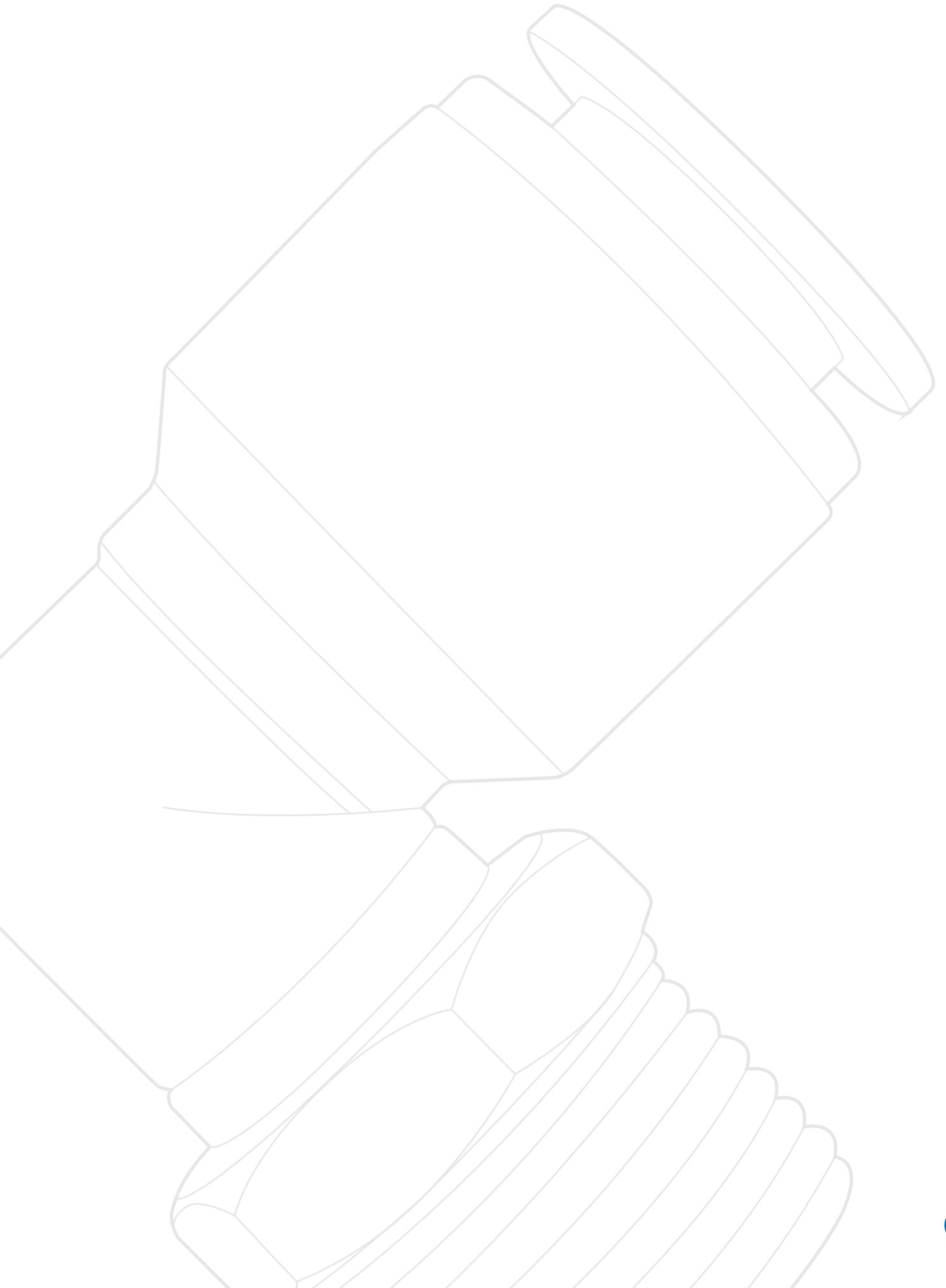

## DATASHEET Ø20,25 &amp; 40



-20°C ÷ +80°C



Max. Working Pressure:

16 Bar

Negative Pressure:

- 0,95 Bar ( - 95 kPa)



Compressed air,  
non-aggressive gases and  
vacuum



- Taper gas BSPT ISO 7  
from R1/2" to R1-1/2"  
- Parallel gas BSPP ISO 228  
from G1/4" to G1"

Body: Reinforced PA  
Aluminum (CA Version)

Tube Seal: NBR

Back Ring: HP technopolymer

Lock Claw: Stainless steel AISI 301

Lock Claw Support: HP technopolymer

Nut Seal: NBR

Nut: Reinforced PA

Screwing Indicator: Silicone

Tube Stop: HP technopolymer  
(CA Version)

## PED

SILICONE FREE



Products in compliance with  
EC Regulation 1907/2006

RoHS3

Products in compliance with  
the directive EU 2015/863

## CONSTRUCTION DETAILS

## Standard Version

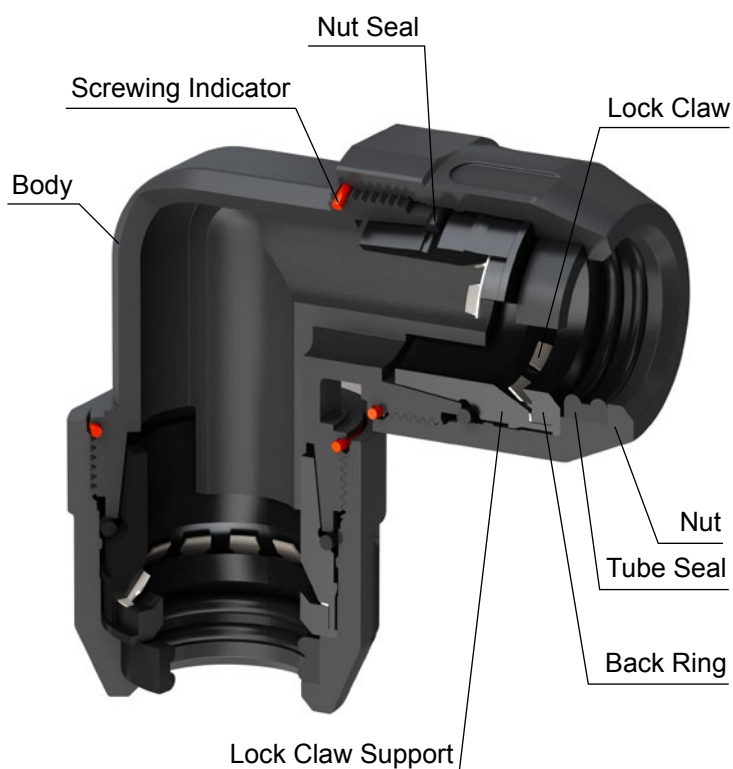

## CA Version

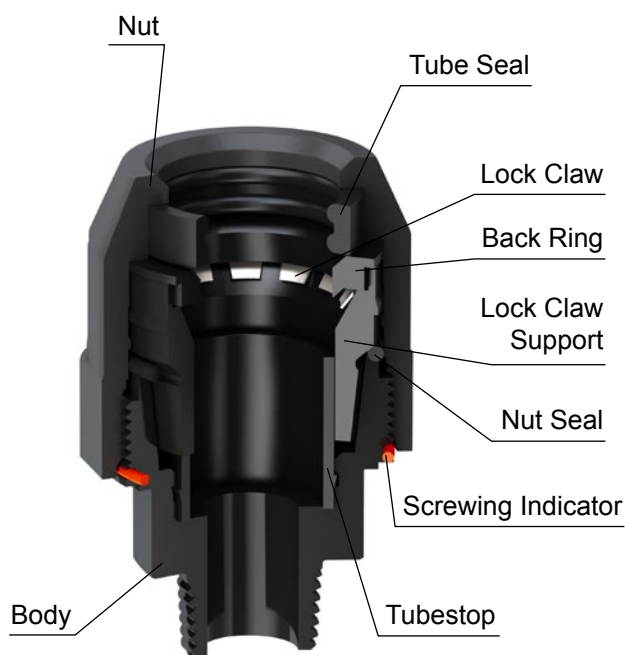

DATASHEET Ø63



-20°C ÷ +80°C



Max. Working pressure:  
16 Bar  
Negative pressure:  
- 0,95 Bar (- 95 kPa)



Compressed air,  
non-aggressive gases and  
vacuum



- Taper gas BSPT ISO 7  
R2-1/2"  
- Parallel gas BSPP ISO 228  
from G1/2" to G2"

Body: Reinforced PA  
Aluminum (CA Version)

Lock Claw: Stainless steel AISI 301



Lock Claw Support: HP technopolymer

O-ring: NBR

Nut: Reinforced PA

Screwing Indicator: Silicone

PED

SILICONE FREE



Products in compliance with  
EC Regulation 1907/2006

RoHS3

Products in compliance with  
the directive EU 2015/863

CONSTRUCTION DETAILS

Standard Version

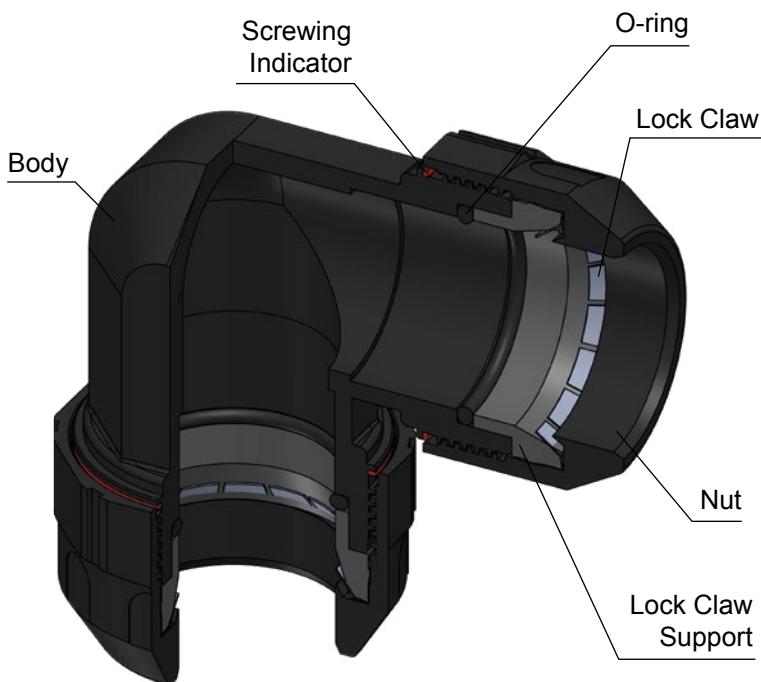

CA Version

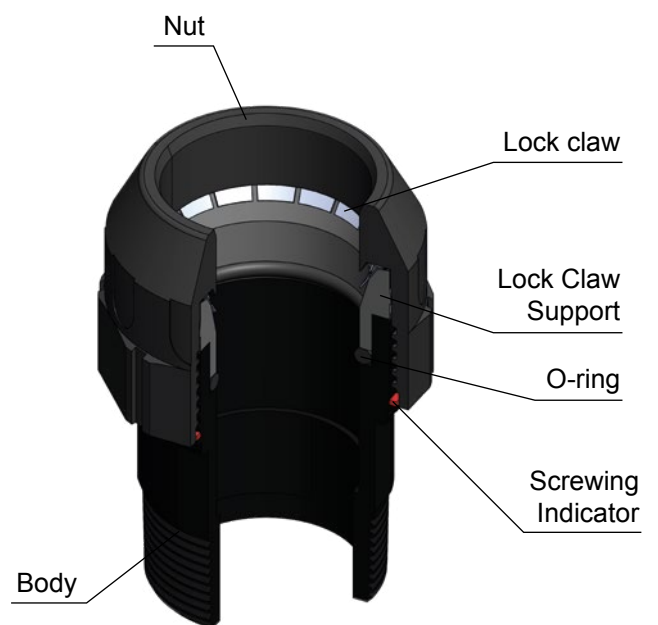

## FPC

## Male connector BSPT thread

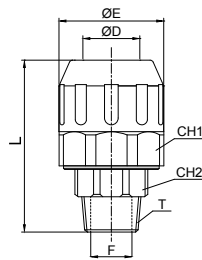

CODE	ØD	T	L	ØF	ØE	CH1	CH2	WEIGHT (g)
FPC20R04	20	R 1/2"	64	14	40,5	39	26	44,5
FPC25R04	25	R 1/2"	70,5	14	48	46	32	72
FPC25R05	25	R 3/4"	75,5	18	48	46	32	74
FPC40R06	40	R 1"	113,2	21	70	67	36	201

## FPCA

## Male connector BSPT thread, aluminum body

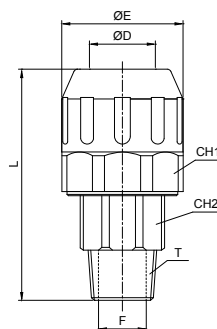

CODE	ØD	T	L	ØF	ØE	CH1	CH2	WEIGHT (g)
FPCA25R06	25	R 1"	88	21	48	46	36	141
FPCA40R08	40	R 1" 1/2"	116,1	36	70	67	50	312
FPCA63R10	63	R 2" 1/2"	129,5	59	102	98	75	680

## FPUC

## Union connector

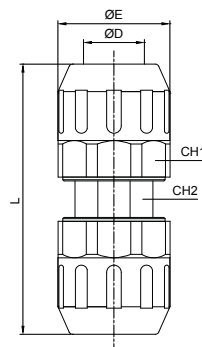

CODE	ØD	L	ØE	CH1	CH2	WEIGHT (g)
FPUC20	20	95	40,5	39	26	81,5
FPUC25	25	111	48	46	32	132
FPUC40	40	171,4	70	67	46	388
FPUC63	63	176	102	98	75	720

## FPG

## Reduced union connector

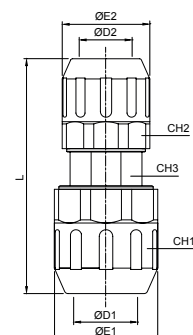

CODE	ØD1	ØD2	ØE1	ØE2	L	CH1	CH2	CH3	WEIGHT (g)
FPG2520	25	20	48	40,5	101,5	46	39	26	103,5
FPG4025	40	25	70	48	136,2	67	46	32	240
FPG6340	63	40	102	70	190,7	98	67	75	580



**FPUL**

Union elbow

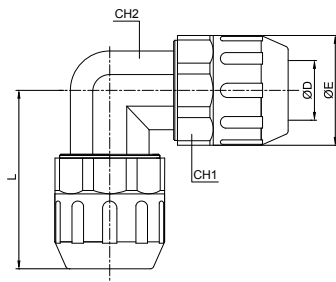

CODE	ØD	ØE	L	CH1	CH2	WEIGHT (g)
FPUL20	20	40,5	63,5	39	26	92,5
FPUL25	25	48	74,8	46	32	152
FPUL40	40	70	110,2	67	46	409
FPUL63	63	102	123,5	98	75	880

**FPULH**

Union elbow 135°

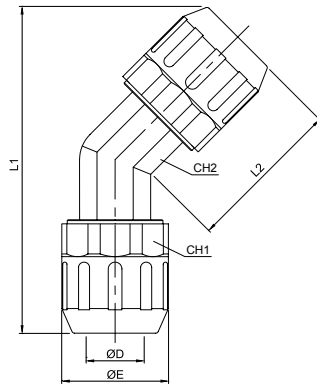

CODE	ØD	ØE	L1	L2	CH1	CH2	WEIGHT (g)
FPULH20	20	40,5	111	53,5	39	26	89
FPULH25	25	48	131	63	46	32	140,5
FPULH40	40	70	201	98,2	67	46	387

**FPUT**

Union tee

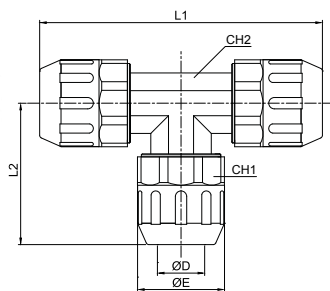

CODE	ØD	L1	L2	ØE	CH1	CH2	WEIGHT (g)
FPUT20	20	127	63,5	40,5	39	26	135
FPUT25	25	149,6	74,8	48	46	32	221
FPUT40	40	220,4	110,2	70	67	46	619
FPUT63	63	247	123,5	102	98	75	1220

**FPGT**

Reduced union tee

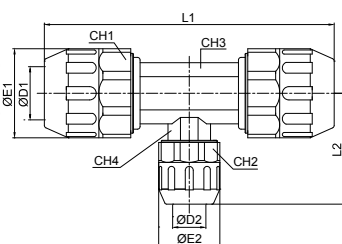

CODE	ØD1	ØD2	L1	L2	ØE1	ØE2	CH1	CH2	CH3	CH4	WEIGHT (g)
FPGT4025	40	25	220,4	83,4	70	48	67	46	46	32	479
FPGT6340	63	40	247	124,7	102	70	98	67	75	46	1040



## FPGT-G

## Female tee BSP thread

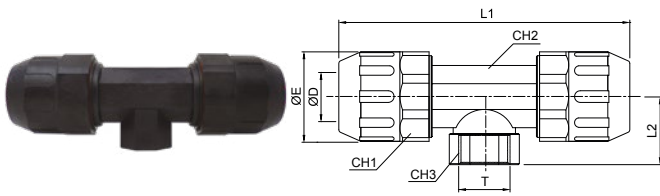

CODE	ØD	T	ØE	L1	L2	CH1	CH2	CH3	WEIGHT (g)
FPGT25G05	25	G 3/4"	48	149,6	43	46	32	36	161,5
FPGT40G06	40	G 1"	70	220,4	44	67	46	46	420
FPGT63G09	63	G 2"	102	247	67,5	98	75	75	1160

## FPPF

## End plug

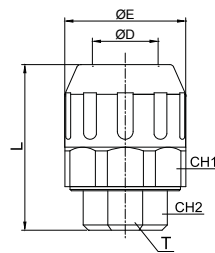

CODE	ØD	T *	L	ØE	CH1	CH2	WEIGHT (g)
FPPF20	20	G 1/4"	56,5	40,5	39	24	46
FPPF25	25	G 1/4"	63	48	46	24	72
FPPF40	40	G 1/4"	88,2	70	67	24	187
FPPF63	63	G 1/4"	107	102	98	75	400

\* Blind thread

## FPBR

## Quick branch

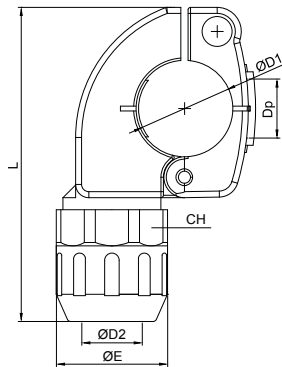

CODE	ØD1	ØD2	L	Dp	ØE	CH	WEIGHT (g)
FPBR2520	25	20	112	18,6	40,5	39	241
FPBR4020	40	20	122	24,5	40,5	39	278
FPBR4025	40	25	130,4	24,5	48	46	290
FPBR6325	63	25	152	24,5	48	46	440

## FPBR-G

## Quick branch female BSP thread

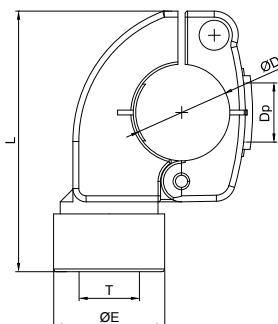

CODE	ØD	T	L	Dp	ØE	WEIGHT (g)
FPBR25G04	25	G 1/2"	90	18,6	34	232,5
FPBR40G05	40	G 3/4"	100	24,5	40,5	287
FPBR63G04	63	G 1/2"	122	24,5	34	380

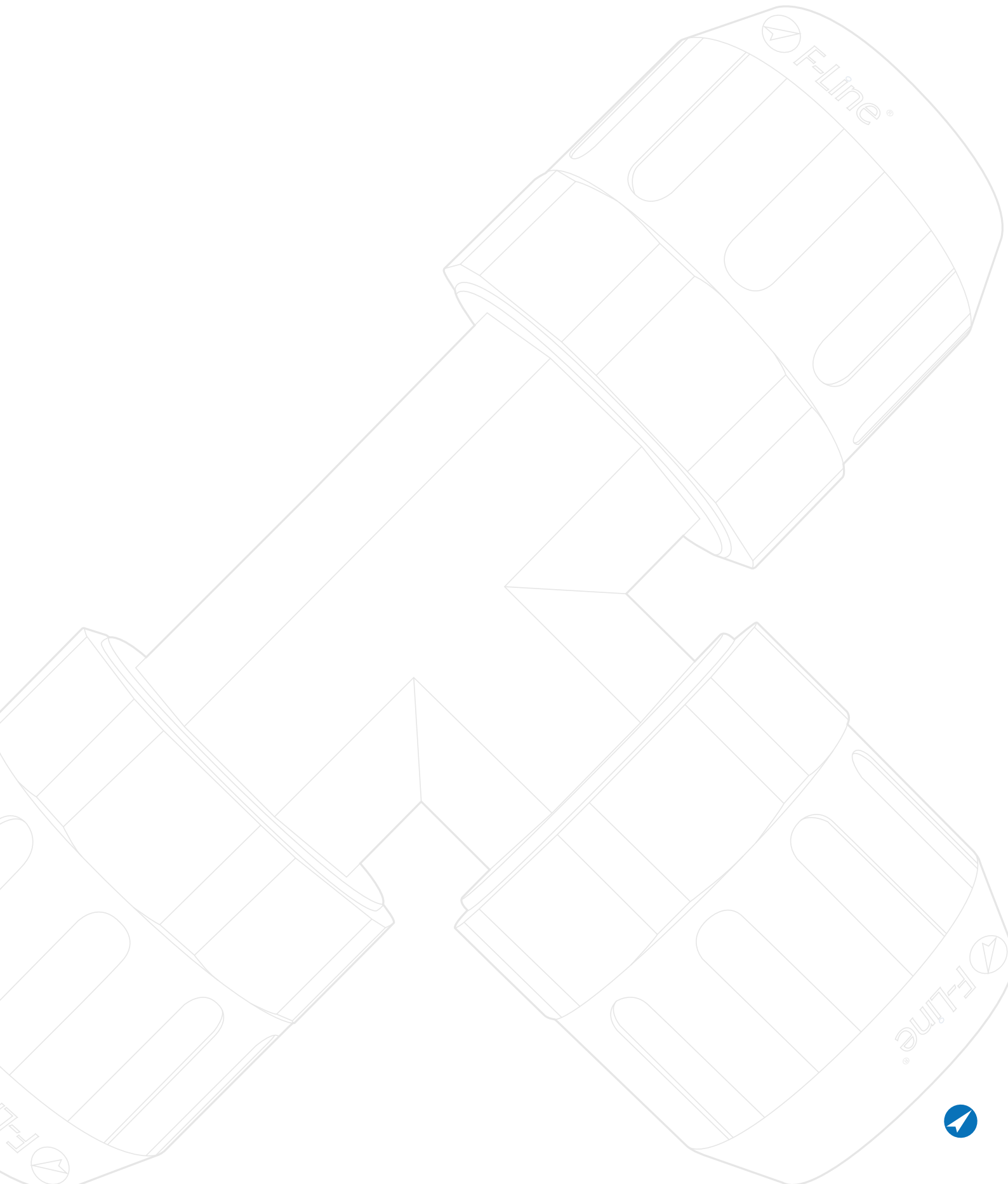

## FPWLM1

Single applique - Aluminum

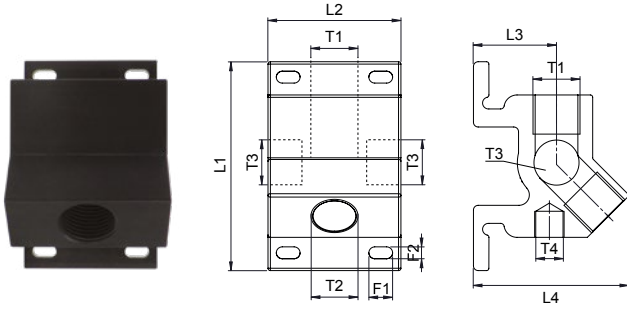

CODE	T1	T2	T3	*T4	L1	L2	L3	L4	F1	F2	WEIGHT (g)
FPWLM1-G04G04	G 1/2"	1xG 1/2"	G 1/2"	G 1/4"	88	56	35	66	10	5	325

\* Blind thread

## FPWLM2

Double applique - Aluminum

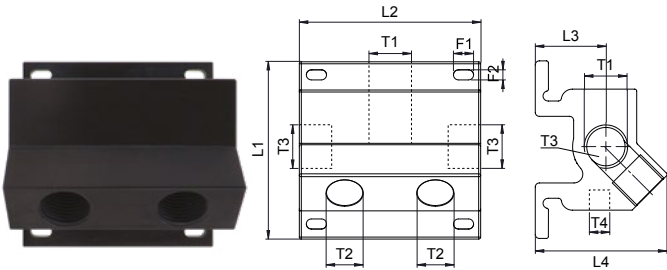

CODE	T1	T2	T3	*T4	L1	L2	L3	L4	F1	F2	WEIGHT (g)
FPWLM2-G04G04	G 1/2"	2xG 1/2"	G 1/2"	G 1/4"	88	90	35	65,7	10	5	530
FPWLM2-G05G04	G 3/4"	2xG 1/2"	G 1/2"	G 1/4"	88	90	35	65,7	10	5	515

\* Blind thread





 0°C ÷ 100°C

 Working pressure:  
16 Bar

 Compressed air and  
non-aggressive gases

 Parallel gas BSPP ISO 228  
G1/2" and G1"

 Body: Stainless steel AISI 304

 Products in compliance with  
EC Regulation 1907/2006

 Products in compliance with  
the directive EU 2015/863

## CONSTRUCTION DETAILS

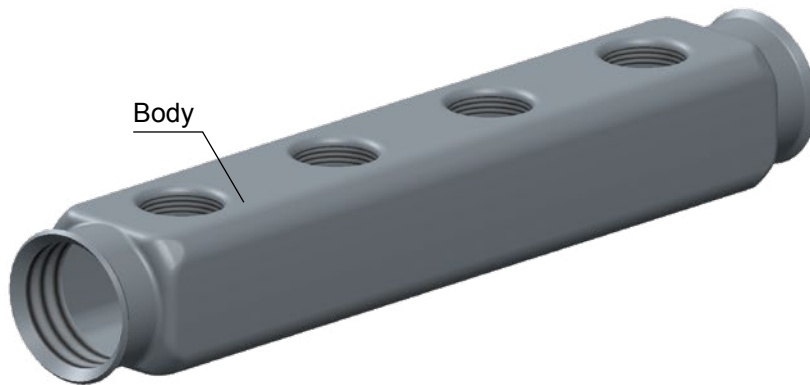

## FPMAN

Distribution manifold BSPP thread in stainless steel AISI 304

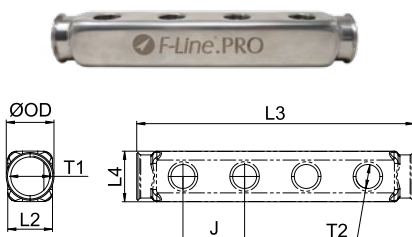

CODE	T1	T2	OUTLETS	J	L1	L2	L3	L4
FPMAN4-G06G04	G 1"	G 1/2"	4	50	38,7	36,3	225	41



**FPSTMAN**

## Set of two brackets for FPMAN manifold

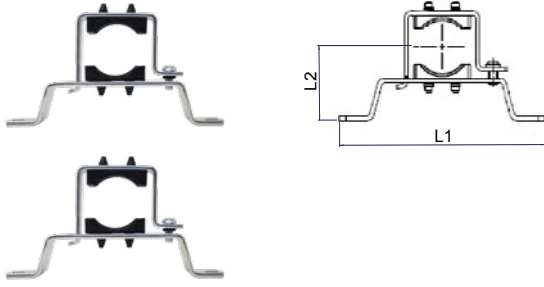

CODE	Ø	L1	L2	WEIGHT (g)
FPSTMAN06-48	1"	140	48	119



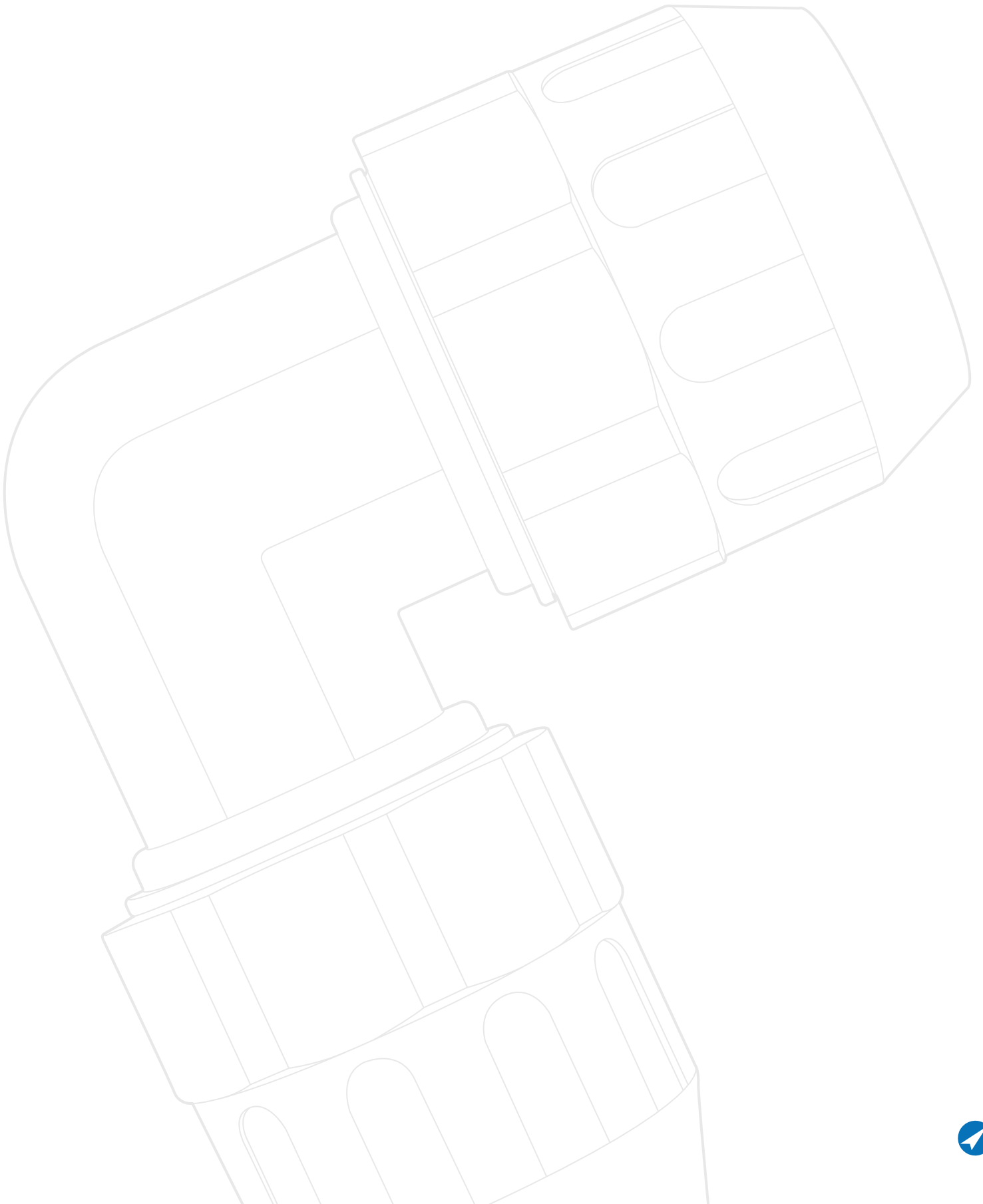



-20°C ÷ +150°C



Working pressure:

16 Bar

Negative pressure:

-0,95 Bar ( - 95 kPa)



Compressed air,  
non-aggressive gases and  
vacuum

Resistant to mechanical shocks and U.V.  
Fire resistance. Non-flammable with no  
propagation of flame.



Material: Stainless steel AISI 316L

## PED

**SILICONE FREE**



Products in compliance with  
EC Regulation 1907/2006



Products in compliance with  
the directive EU 2015/863

### USE OF THE FPAX PIPE WITH F-LINE®.PRO FITTINGS

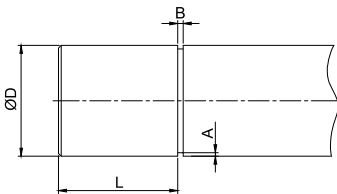

The ends of the tube must be deburred to prevent cuts or other damage to the O-rings. Make an incision as shown in the drawing, at the distance specified in the table according to the fitting's nominal diameter (ØD).

ØD (mm)	L (mm)	B (mm)	A (mm)
16	8,5	1	0,4

### FPAX

Stainless steel pipe 5,7 meters

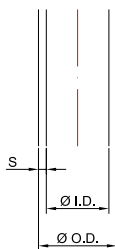



CODE	ØOD	ØID	S	WEIGHT (g/m)
FPAX1614	16	14	1	390

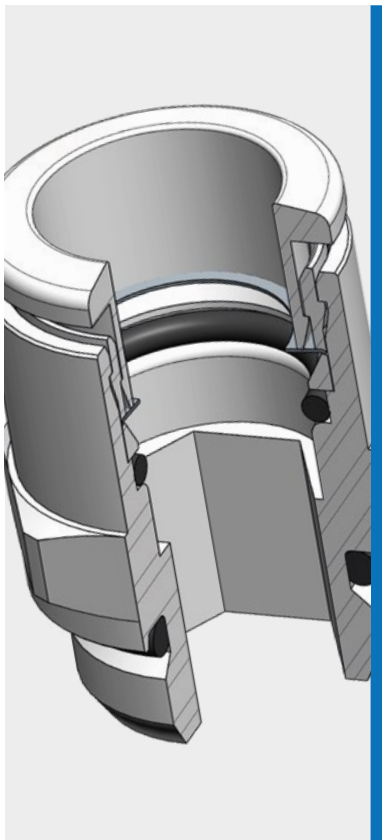



 -20°C ÷ 150°C

 Working pressure:  
20 Bar  
Negative pressure:  
- 0,95 Bar (- 95 Kpa)

 Compressed air,  
non-aggressive gases and  
vacuum

 Parallel gas BSPP ISO 228  
G1/2"

- Body: Stainless steel AISI 316L
- Collet: Stainless steel AISI 316L
- Collar: Stainless steel AISI 316L
- Lock claw: Stainless steel AISI 301
- Back ring: Stainless steel AISI 316L
- O-ring: EPDM Perox

 BPA FREE

 PFAS FREE

 SILICONE FREE



Products in compliance with  
EC Regulation 1907/2006



Products in compliance with  
the directive EU 2015/863

## CONSTRUCTION DETAILS

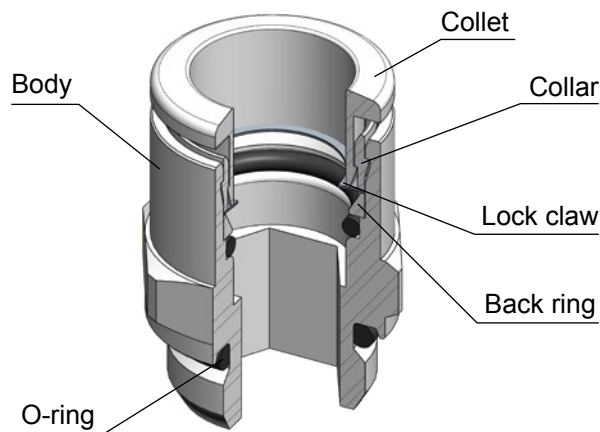

## XVHRCPRO-G

### Male connector BSPP thread

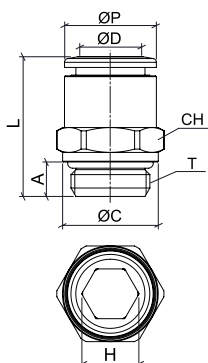

CODE	ØD	T	ØP	ØC	A	L	CH	H
XVHRCPRO16G04	16	G 1/2"	24	25	9	36,5	25	13



**1410PRO**

## Nipple BSPT thread - Stainless steel AISI 316

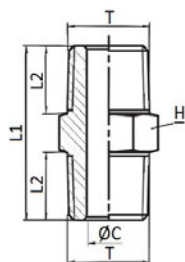

CODE	T	ØC	L1	L2	H	WEIGHT (g)
1410PRO12	R 1/2"	13	38	15	22	58

**1412PRO**

## Reduced nipple BSPT thread - Stainless steel AISI 316

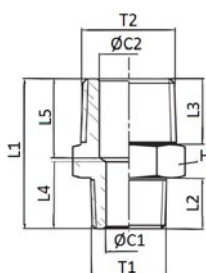

CODE	T1	T2	ØC1	ØC2	L1	L2	L3	L4	L5	H	WEIGHT (g)
1412PRO1234	R 1/2"	R 3/4"	13	18	43	15	18	19,6	22	27	87,1

**FPSAS**

## Single applique - Stainless steel AISI 316

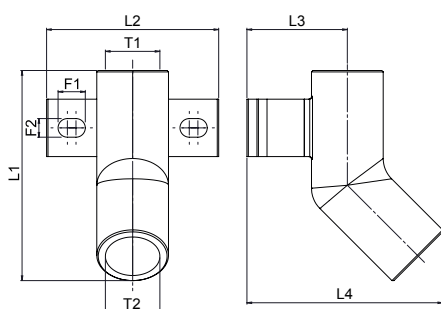

CODE	T1	T2	L1	L2	L3	L4	F1	F2	WEIGHT (g)
FPSAS-G04G04	G 1/2"	G 1/2"	73,5	60	35	68,5	9,5	6,5	159

**FPDAS**

## Double applique - Stainless steel AISI 316

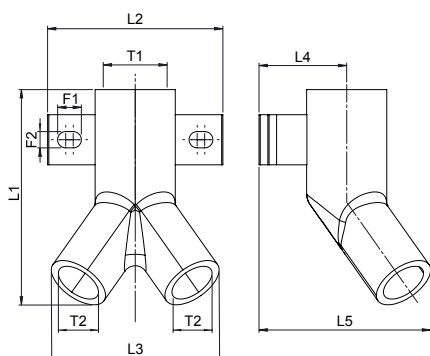

CODE	T1	T2	L1	L2	L3	L4	L5	F1	F2	WEIGHT (g)
FPDAS-G05G04	G 3/4"	G 1/2"	86	70	67	35	68,5	9,5	6,5	265



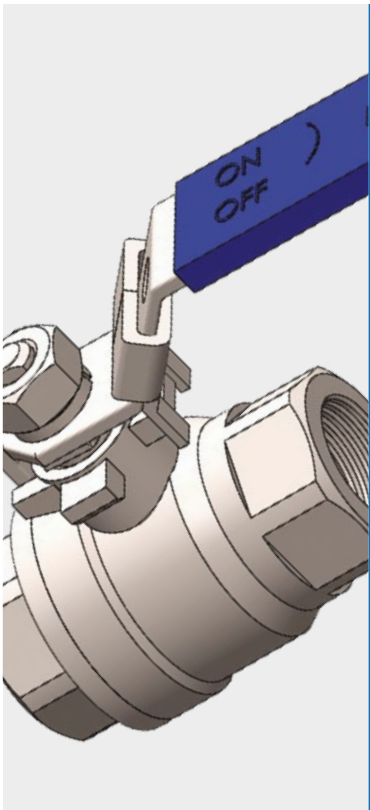

-25°C ÷ 180°C



Working pressure:  
85 Bar



Compressed air,  
non-aggressive gases and  
vacuum



Parallel gas BSPP ISO 228-1  
G1/2"



- Body: Stainless steel AISI 316
- Stem: Stainless steel AISI 316
- Body end: Stainless steel AISI 316
- Ball: Stainless steel AISI 316
- Seat: PTFE
- Handle: Stainless steel AISI 316
- Nut: Stainless steel AISI 316
- Stem seal: PTFE
- Seal: PTFE
- Packing nut: Stainless steel AISI 316
- Locking: Stainless steel AISI 316



Products in compliance with  
EC Regulation 1907/2006



Products in compliance with  
the directive EU 2015/863

## CONSTRUCTION DETAILS

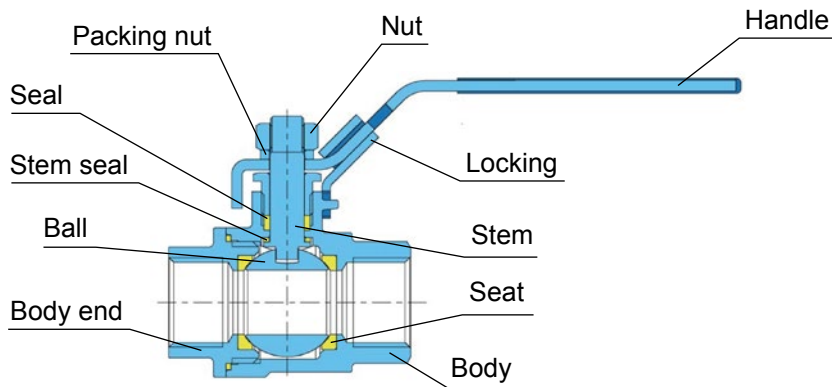

## 9320PRO

Universal full bore ball valve, female BSPP thread, blue lever

CODE	T	DN	A	L1	L2	L3
9320PRO12	G 1/2"	15	12,5	57,0	56,0	105,0

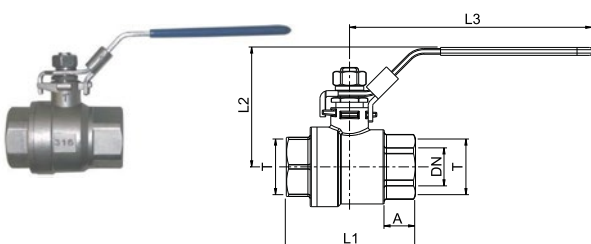

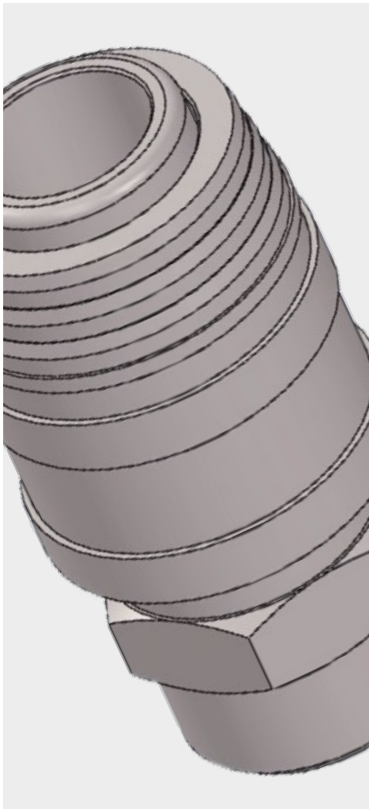

20°C ÷ 205°C



Working pressure:  
0-12 Bar (suggested)  
35 Bar (max)



Taper gas BSPT ISO 7  
from R1/4" to R1/2"



Compressed air, water, grease,  
oils, mild acids, applications in  
highly oxidising or corrosive  
environments and fluids suitable  
with construction materials

Body: Stainless steel AISI 316  
Slide: Stainless steel AISI 316  
Adapter: Stainless steel AISI 316  
Valve: Stainless steel AISI 316  
Spring: Stainless steel AISI 316  
Ball: Stainless steel AISI 316  
Retaining ring: Stainless steel AISI 316  
Seal: FKM  
Connection (AEU-75-PRO): Stainless steel AISI 316



## PROFILE

Germany

## NOMINAL DIAMETER

7,6 mm

## FLOWRATE

1125 l/min (EU-75N)

## CONFIGURATION

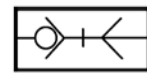

SO  
Single  
Shutter



Products in compliance with  
EC Regulation 1907/2006



Products in compliance with  
the directive EU 2015/863

## EU-75N-PRO

## Male quick coupling BSPT thread

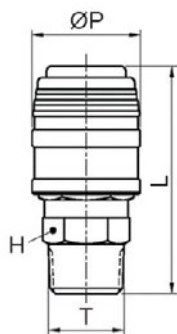

CODE	T	ØP	L	H
EU-75N-PRO-R04-316V	R 1/2"	24,4	57,2	22



## AEU-75M-PRO

Male connection BSPT thread

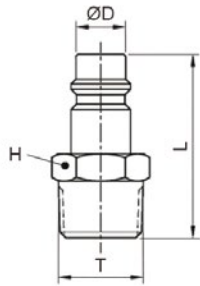

CODE	T	ØD	L	H
AEU-75M-PRO-R02-316	R 1/4"	10	36,5	14
AEU-75M-PRO-R03-316	R 3/8"	10	37,0	17
AEU-75M-PRO-R04-316	R 1/2"	10	42,0	22

## AEU-75H-PRO

Female connection BSPP thread

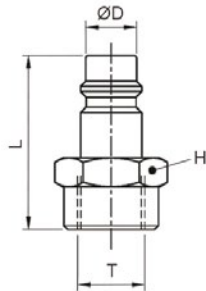

CODE	T	ØD	L	H
AEU-75H-PRO-G02-316	G 1/4"	10	34,0	17
AEU-75H-PRO-G03-316	G 3/8"	10	34,5	22
AEU-75H-PRO-G04-316	G 1/2"	10	40,0	24

## AEU-75E-PRO

Connection with barb connector

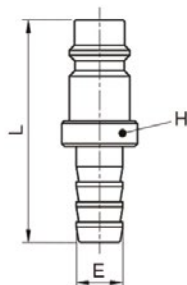

CODE	INT. TUBE Ø	E	L	H
AEU-75E-PRO10-316	10	11,2	48,0	15
AEU-75E-PRO12-316	12	13,2	48,0	17





9210 - 9220 - 9250  
 -20°C ÷ +150°C  
 9210PRO - 9220PRO  
 -20°C ÷ +80°C  
 FP1610  
 -5°C ÷ +70°C  
 9120  
 0°C ÷ +60°C  
 9611  
 -10°C ÷ +110°C



PN (Nominal Pressure)  
 See the table



Compressed air and  
 non-aggressive gases



- Taper gas BSPT ISO 7  
 from R1/4" to R3/4"  
 - Parallel gas BSPP ISO 228-1  
 from G1/4" to G2-1/2"

9210 - 9220 - 9250

Body: Nickel plated brass  
 Body end: Nickel plated brass  
 Seat: PTFE  
 Ball: Chrome plated brass  
 Stem: Nickel plated brass  
 O'Ring: NBR  
 Seal: PTFE  
 Packing nut: Nickel plated brass  
 Handle: Steel  
 Nut: Steel



FP1610

Body: Chrome plated brass  
 Slide: Black anodized aluminum  
 O'Ring: NBR 70  
 Elastic ring: Steel

1110 & 1112

Body: Nickel plated brass



Products in compliance with EC  
 Regulation 1907/2006



Products in compliance with  
 the directive EU 2015/863

## 9210PRO

### Full bore ball valve with fittings - blue lever

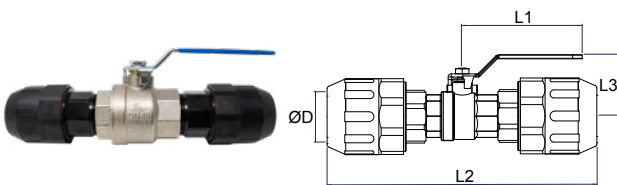

CODE	ØD	DN	PN	L1	L2	L3	WEIGHT (g)
9210PRO25	25	21	16	115	216	59	704
9210PRO40	40	36	16	150	290	75	1583
9210PRO63	63	59	16	200	342	108	-

For fittings construction details & technical datasheet,  
 please refer to page 42 and 43.

## 9220PRO

### Full bore ball valve with fitting and male BSPP thread - blue lever

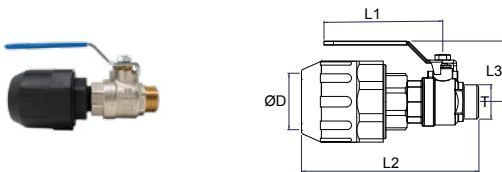

CODE	ØD	T	DN	PN	L1	L2	L3	WEIGHT (g)
9220PRO20G04	20	G 1/2"	14	16	92	102,5	43	217
9220PRO25G04	25	G 1/2"	14	16	92	108,5	43	246
9220PRO25G05	25	G 3/4"	18	16	92	121	47	319
9220PRO25G06	25	G 1"	21	16	115	143	59	554
9220PRO40G08	40	G 1-1/2"	36	16	150	191	75	1242

For fittings construction details & technical datasheet,  
 please refer to page 42.



### 9120

### Brass miniball valve M/F, BSPP thread

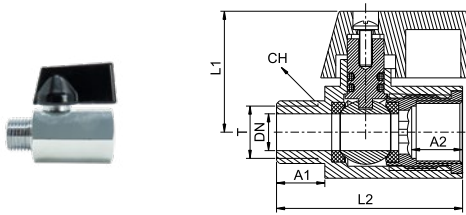

CODE	T	PN	DN	A1	A2	L1	L2	CH	WEIGHT (g)
9120PRO14	G 1/4"	16	8	10	10	26	40,5	20	74

### 9611

### Brass drain valve, BSPT thread

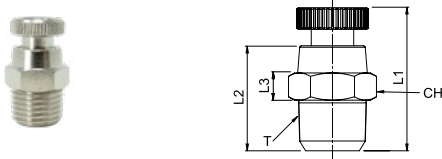

CODE	T	PN	L1	L2	L3	CH	WEIGHT (g)
9611PRO14	R 1/4"	16	24	16	5	14	20

### 9210

### Full bore ball valve, threaded ends BSPP F/F - blue lever

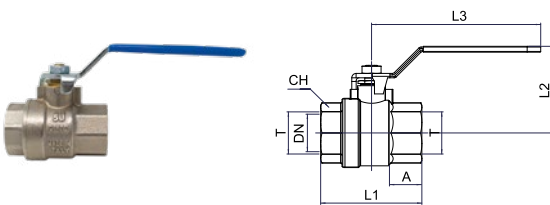

CODE	T	DN	PN	A	L1	L2	L3	CH	WEIGHT (g)
9210PRO12	G 1/2"	15	50	11	50	43	92	25	158
9210PRO34	G 3/4"	20	50	13	57	47	92	31	255
9210PRO1	G 1"	25	40	15	70	59	115	38	422
9210PRO112	G 1-1/2"	40	32	18	90	75	150	54	959
9210PRO2	G 2"	50	32	20	107	82	150	66	-
9210PRO212	G 2-1/2"	60	16	22	132	108	200	84	-

### 9220

### Full bore ball valve, threaded ends BSPP M/F - blue lever

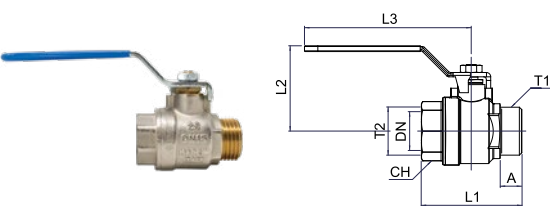

CODE	T1	T2	DN	PN	A	L1	L2	L3	CH	WEIGHT (g)
9220PRO12	G 1/2"	G 1/2"	15	50	10,5	50	43	92	25	174
9220PRO34	G 3/4"	G 3/4"	20	50	13	58	47	92	31	245
9220PRO1	G 1"	G 1"	25	40	15	70	59	115	38	413
9220PRO112	G 1-1/2"	G 1-1/2"	40	32	18	91	75	150	54	930
9220PRO2	G 2"	G 2"	50	32	20	107	82	150	66	-

### 9250

### Full bore ball valve, threaded ends BSPP M/F - blue butterfly lever

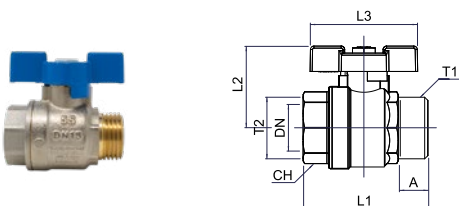

CODE	T1	T2	DN	PN	A	L1	L2	L3	CH	WEIGHT (g)
9250PRO12	G 1/2"	G 1/2"	15	50	10,5	50	43	50	25	153
9250PRO34	G 3/4"	G 3/4"	20	50	13	58	47	50	31	224
9250PRO1	G 1"	G 1"	25	40	15	70	59	61	38	364



## FP1610

## Slide valve BSPP thread

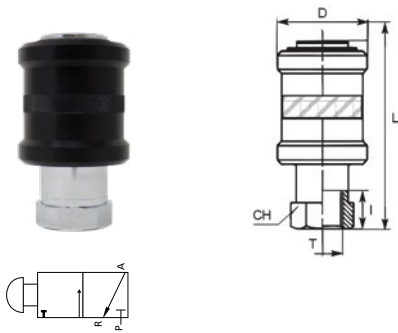

CODE	T	PN	D	L	I	CH	FLOW (NI/min)	WEIGHT (g)
FP1610TR12	G 1/2"	10	40	75	15	27	3800	212
FP1610TR34	G 3/4"	10	50	83	16,5	32	5700	317

## 1110

## Nipple BSPT thread

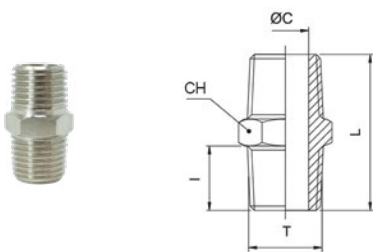

CODE	T	ØC	L	I	CH	WEIGHT (g)
1110PRO12	R 1/2"	15	30,5	12,5	22	79
1110PRO34	R 3/4"	20	34,5	14	27	61

## 1112

## Reduced nipple BSPT thread

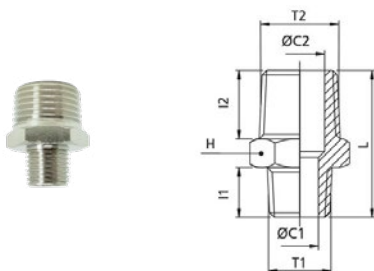

CODE	T1	T2	ØC1	ØC2	L	I1	I2	H	WEIGHT (g)
1112PRO1234	R 1/2"	R 3/4"	15	20	32,5	12,5	14	27	58



**FPFD**

Drilling tool and template



CODE	Ø TUBE	Ø HOLE	WEIGHT (g)
FPFD25	25	18	132,5
FPFD4063	40 - 63	24	155

**FPCH**

Wrench for nut fittings tightening

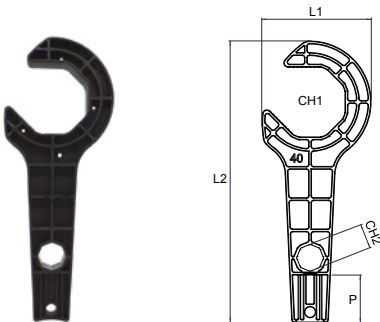

CODE	DN	CH1	L1	L2	* P	CH2	WEIGHT (g)
FPCH20	20	39	66	170	24,5	-	104
FPCH25	25	46	75	200	29	-	153
FPCH40	40	67	105	270	45,5	24	269

\* Tube insertion depth marking function included

CH2: Hexagon for use with FPPF end plug only available on FPCH40 (Ø40)

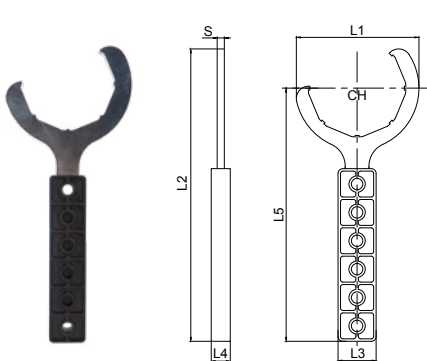

CODE	DN	CH1	L1	L2	L3	L4	L5	S	WEIGHT (g)
FPCH63	63	98,5	128,8	307	40	20	266	7,5	269

**FPCCH**

Wrench for Ø63 body fittings locking

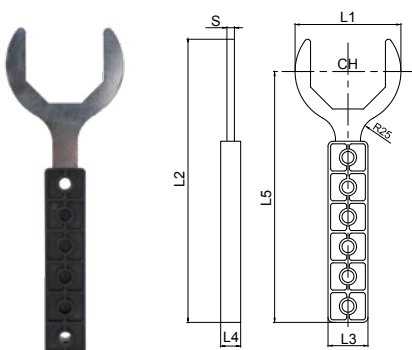

CODE	DN	CH1	L1	L2	L3	L4	L5	S	WEIGHT (g)
FPCCH63	63	75	106	283,5	40	20	251,2	7,5	104



**FPTT**

## Metal pipe cutter



CODE	Ø MIN.	Ø MAX.	WEIGHT (g)
FPTT1632	16	32	350
FPTT1663	16	63	800

**FPUS**

## Beveling cone



CODE	Ø MIN.	Ø MAX.	WEIGHT (g)
FPUS1650	16	50	428

**FPHBT**

## Hand beveling



CODE	WEIGHT (g)
FPHBT	30,5



**R-PTFEPRO**

Teflon tape for professional use



CODE	THICKNESS	WIDTH	CONTAINER
R-PTFEPRO190215	0,2 mm	3/4"	15 m

**TEMPERATURE**

-200°C ÷ +260°C

**FEATURES**

The PTFE thread sealing tape of unsintered PTFE is mainly used as a thread sealing element. It resists all known chemical compound and solvents, with the exception of gaseous Flourine at high temperature, Trifluoro Chlorine, alkali metals either molten or in solution. It can be used in a temperature range: -200°C to +260°C; has a low coefficient of friction, is tasteless, insolubile, and doesn't smell. The tapes are normally available on plastic reels. Is compounded from virgin material and is produced through a process called "Paste Extrusion".

**LOXPRO1810**

Low strength PTFE anaerobic adhesive for sealing of metal thread pipe joints



CODE	HANDLING TIME	FUNCTIONAL CURE TIME	FULL CURE TIME	MAX THREAD Ø / GAP FILLING	CONTAINER
LOXPRO1810	20 - 40 min	1 - 3 hours	5 - 10 hours	2" / 0,30 mm	75 ml

**TEMPERATURE**

-55°C ÷ +150°C

**FEATURES**

Anaerobic adhesive for sealing of metal thread pipe joints. Suitable for gas, LP gas, compressed air, gasoline and oil, industrial fluids, CFC, water and several chemicals. Low friction coefficient will assure easy assembly. Thixotropic property prevents migration from thread of the sealant before or during curing. It replaces P.T.F.E. tape and yarn. Cured product provides elastic film. Shocks and vibrations resistant; unaffected sealing properties in the temperature range from -55 to +150°C. Easy dismantling is assured even after years.





5°C ÷ +60°C

Max. working pressure:  
10 Bar

Compressed air

FPF filters are used for filtering from particles and condensing the impurity inside compressed air. The big surface of filtering element allows to keep constant the flow rate even in hard working conditions. The condensed moisture discharge is manual when the filter is pressurized and automatic when it is depressurized. On request it can be completely automatic.

Body: Aluminum

Bowl: Polycarbonate (FPFP02)

Polycarbonate with steel protection (FPFM04)

Drain mode: Brass and ABS

Seal: NBR

Whirlpool element: ABS

Filter: Sinterized bronze

Products in compliance with  
EC Regulation 1907/2006Products in compliance with  
the directive EU 2015/863

CODE	NOMINAL FLOW RATE *	BLOW CAPACITY	FILTER DEGREE
FPFP02	750 NI/min	15 cm <sup>3</sup>	25 µm
FPFM04	4000 NI/min	45 cm <sup>3</sup>	25 µm

\* Flow rate measured with an inlet pressure of 7 bar and an outlet pressure of 5 bar

**FLOW CHART**  
**FPFP02**

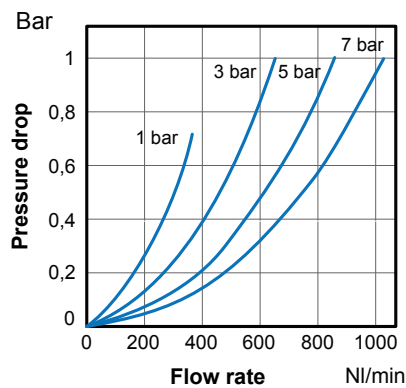

**FLOW CHART**  
**FPFM04**

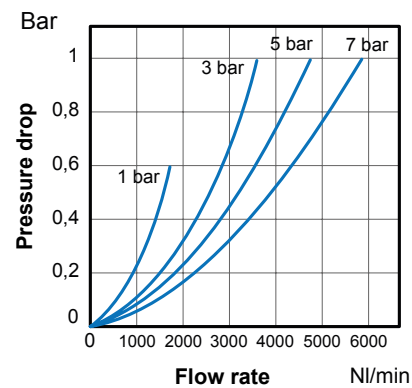

**FPF**

**Filter**

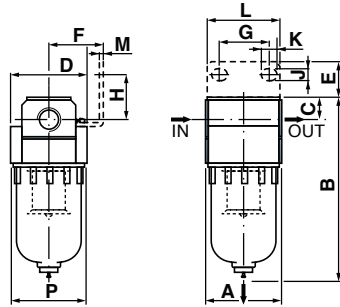

CODE	THREAD	A	B	C	D	E	F	G	H	J	K	L	M	P	WEIGHT (g)
FPFP02	G 1/4"	40	98	11	40	17	30	26	22	5,5	8,5	40	2,3	40	190

**FPFM**

**Filter with steel protection**

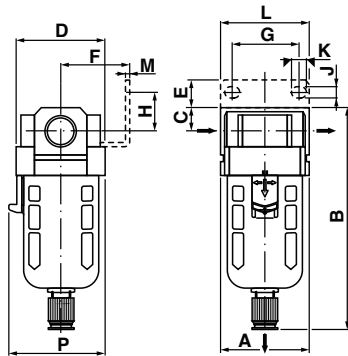

CODE	THREAD	A	B	C	D	E	F	G	H	J	K	L	M	P	WEIGHT (g)
FPFM04	G 1/2"	70	169	18	70	17	50	54	26	8,5	10,5	70	2,3	73	550





 5°C ÷ +60°C

 Max. working pressure:  
10 Bar

 Compressed air

Pressure regulators are used to maintain a constant downstream pressure and get the best performance avoiding any energy wasting.

Reducers can be placed inside the control panels thanks to their ease in fixing with the proper brackets; moreover pressure can be fixed safely by means of a knob locking system.

- Body: Aluminum
- Diaphragm: NBR
- Spring: Zinc-plated steel
-  Handle: Charged nylon
- Ring nut: Plastic (FPRP02 and FPRPG02)  
Aluminum (FPRP04 and FPRPG04)
- Seal: NBR
- Shutter: Brass - NBR

-   Products in compliance with EC Regulation 1907/2006
-  **RoHS3** Products in compliance with the directive EU 2015/863

CODE	NOMINAL FLOW RATE *	ADJUSTMENT RANGE
FPRP02 / FPRPG02	550 NI/min	0,5 - 8,5 Bar
FPRP04 / FPRPG04	6000 NI/min	0,5 - 8,5 Bar

\* Flow rate measured with an inlet pressure of 7 bar and an outlet pressure of 5 bar

**FLOW CHART**  
**FPRP02 / FPRPG02**

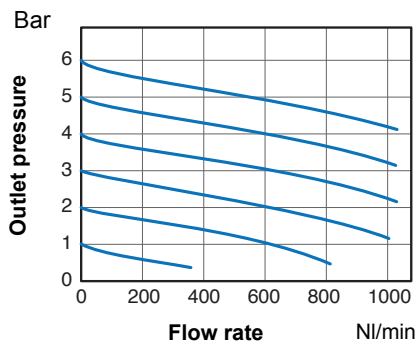

**FLOW CHART**  
**FPRP04 / FPRPG04**

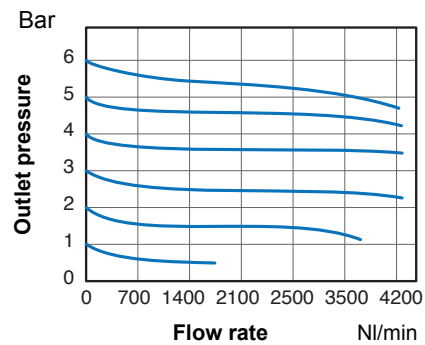

**FPRP**

Pressure regulator

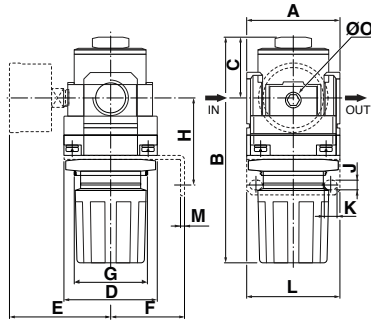

CODE *	THREAD	A	B	C	D	E	F	G	H	J	K	L	M	ØO	WEIGHT (g)
FPRP02	G 1/4"	40	95	17	40	57	30	M32x1,5	44	5,4	15,5	55	2,3	G 1/8"	270
FPRP04	G 1/2"	70	150	38	70	66	50	M52x1,5	54	8,5	10,5	70	2,3	G 1/4"	840

\* Pressure reducer with possibility of additional pressure gauge.

For FPRP02 code: MABP40R0138 pressure gauge (pressure gauge data sheet supplied on request)

For FPRP04 code: MABP50R0238 pressure gauge (pressure gauge data sheet supplied on request)

**FPRPG**

Pressure regulator with integrated pressure gauge

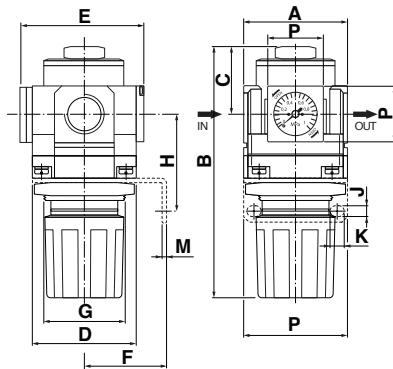

CODE	THREAD	A	B	C	D	E	F	G	H	J	K	L	M	P	WEIGHT (g)
FPRPG02	G 1/4"	40	99	17	40	59	30	M32x1,5	44	5,4	15,5	55	2,3	27	280
FPRPG04	G 1/2"	70	150	38	70	81	50	M52x1,5	54	8,5	10,5	70	2,3	27	900





 5°C ÷ +60°C

 Max. working pressure:  
10 Bar

 Compressed air

Filter regulators combine the functions of a filter and pressure reducer in a single element.

- Body: Aluminum
- Diaphragm: NBR
- Spring: Zinc-plated steel
- Handle: Charged nylon
- Ring nut: Plastic (FPFRP02 and FPFRPG02)
- Aluminium (FPFRM04 and FPRMG04)
- Seal: NBR
- Shutter: Brass - NBR
- Bowl: Polycarbonate (FPFRP02 and FPFRPG02)
- Polycarbonate with steel protection (FPFRM04 and FPRMG04)
- Drain mode: Brass and ABS
- Whirlpool element: ABS
- Filter: Sinterized bronze

 Products in compliance with EC Regulation 1907/2006

 REACH COMPLIANT

 RoHS3 Products in compliance with the directive EU 2015/863

CODE	NOMINAL FLOW RATE *	ADJUSTMENT RANGE	FILTER DEGREE
FPFRP02 / FPFRPG02	550 NI/min	0,5 - 8,5 Bar	25 µm
FPFRM04 / FPRMG04	4000 NI/min	0,5 - 8,5 Bar	25 µm

\* Flow rate measured with an inlet pressure of 7 bar and an outlet pressure of 5 bar

**FLOW CHART**  
**FPFRP02 / FPFRPG02**

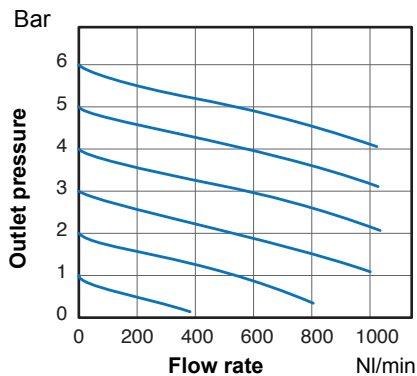

**FLOW CHART**  
**FPFRM04 / FPRMG04**

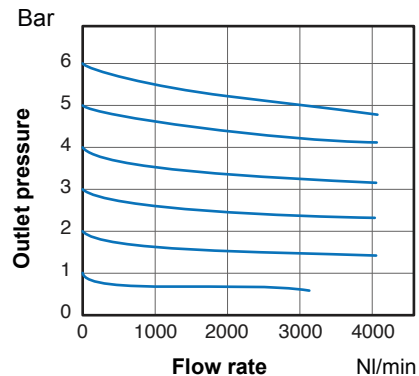

**FPFR**

Filter regulator

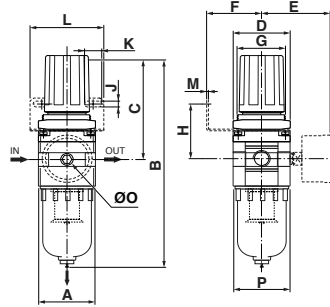

\* Pressure regulators with the possibility of adding a pressure gauge.  
 For FPFRP02 code: MABP40R0138 pressure gauge  
 (pressure gauge data sheet supplied on request)

CODE *	THREAD	A	B	C	D	E	F	G	H	J	K	L	M	P	ØO	WEIGHT (g)
FPFRP02	G 1/4"	40	165	78	40	57	30	M32x1,5	44	5,5	15,5	55	2,3	40	G 1/8"	360

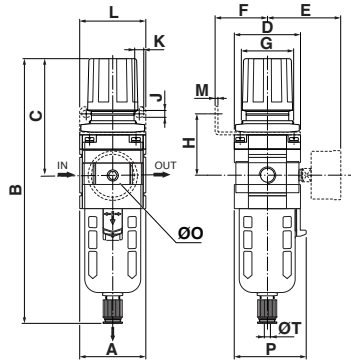

\* Pressure regulators with the possibility of adding a pressure gauge.  
 For FPFRM04 code: MABP50R0238 pressure gauge  
 (pressure gauge data sheet supplied on request)

CODE *	THREAD	A	B	C	D	E	F	G	H	J	K	L	M	P	ØO	ØT	WEIGHT (g)
FPFRM04	G 1/2"	70	262	112	70	71	50	M52x1,5	54	8,5	10,5	70	2,3	73	G 1/4"	8	1150

**FPFRG**

Filter regulator with integrated pressure gauge

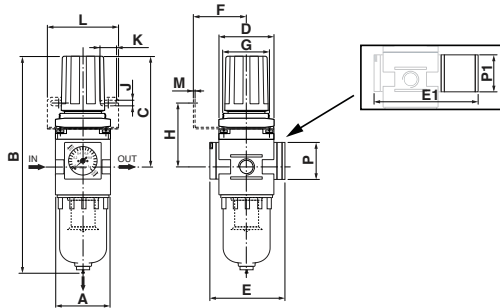

CODE	THREAD	A	B	C	D	E	E1	F	G	H	J	K	L	M	P	P1	WEIGHT (g)
FPFRPG02	G 1/4"	40	99	17	40	59	85	30	M32x1,5	44	5,4	15,5	55	2,3	27	27	380

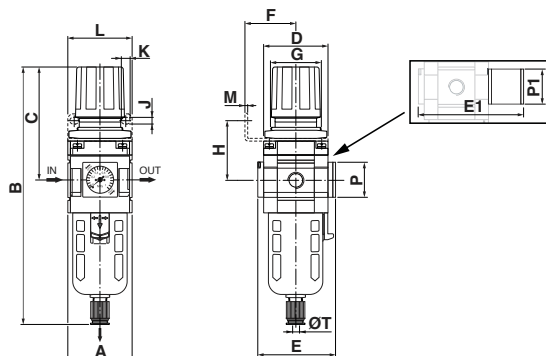

CODE	THREAD	A	B	C	D	E	E1	F	G	H	J	K	L	M	P	P1	ØT	WEIGHT (g)
FPFRMG04	G 1/2"	70	150	38	70	81	107	50	M52x1,5	54	8,5	10,5	70	2,3	27	27	8	1160





5°C ÷ +60°C



Max. working pressure:  
10 Bar



Compressed air

The special shape of the bowl protection allows to see the oil level in the lubricator.  
The flow of the circulating oil can be observed from the see-through window and can be regulated by the special adjustment screw.

Body: Aluminum

Bowl: Polycarbonate (FPLP02)

Polycarbonate with steel protection (FPLM04)



Seal: NBR

Oil filler cap: ABS

Oil screw adjustment: Brass and ABS

Venturi's device: Polyurethane

Venturi element support:

Polyurethane



Products in compliance with  
EC Regulation 1907/2006



Products in compliance with  
the directive EU 2015/863

CODE	NOMINAL FLOW RATE *	BLOW CAPACITY	MIN. FLOW OF OIL DROP
FPLP02	800 NI/min	25 cm <sup>3</sup>	15 NI/min
FPLM04	5000 NI/min	130 cm <sup>3</sup>	50 NI/min

\* Flow rate measured with an inlet pressure of 7 bar and an outlet pressure of 5 bar

**FLOW CHART**  
**FPLP02**

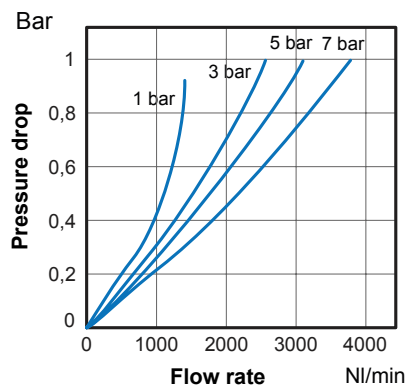

**FLOW CHART**  
**FPLM04**

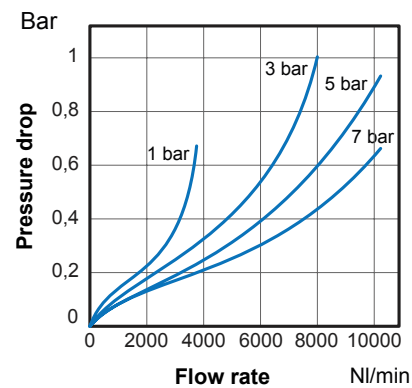

**FPL**

Lubricator

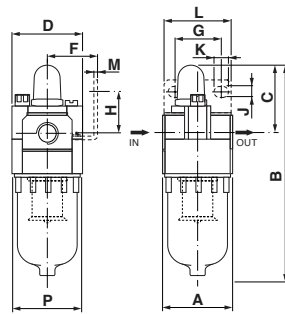

CODE	THREAD	A	B	C	D	F	G	H	J	K	L	M	P	WEIGHT (g)
FPLP02	G 1/4"	40	122	38	40	30	27	22	5,5	8,5	40	2,3	40	220

**FPLM**

Lubricator with steel protection

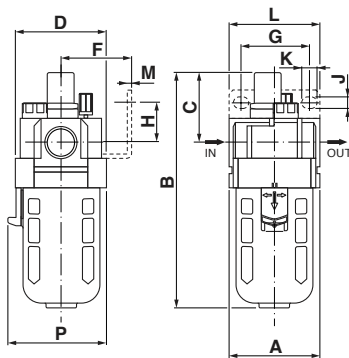

CODE	THREAD	A	B	C	D	F	G	H	J	K	L	M	P	WEIGHT (g)
FPLM04	G 1/2"	70	177	41	70	50	54	26	8,5	10,5	70	2,3	73	560





 5°C ÷ +60°C

 Working pressure:  
From 1,5 Bar to 10 Bar

 Compressed air

The FPSA automatic drain unit is useful to collect and automatically release water produced in a closed branch of a pneumatic circuit. Water releasing is possible either with or without pressure. On the top of the body there is a manual operated valve useful to depressurize cup before the maintenance operations.

 Body: Aluminum  
Tazza: Polycarbonate with steel protection

  Products in compliance with EC Regulation 1907/2006

 Products in compliance with the directive EU 2015/863

## FPSA

## Automatic drain unit

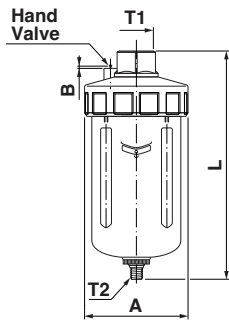

CODE	T1	T2	A	B	L	WEIGHT (g)
FPSA04	G 1/2"	G 1/8"	72	2,5	162	400



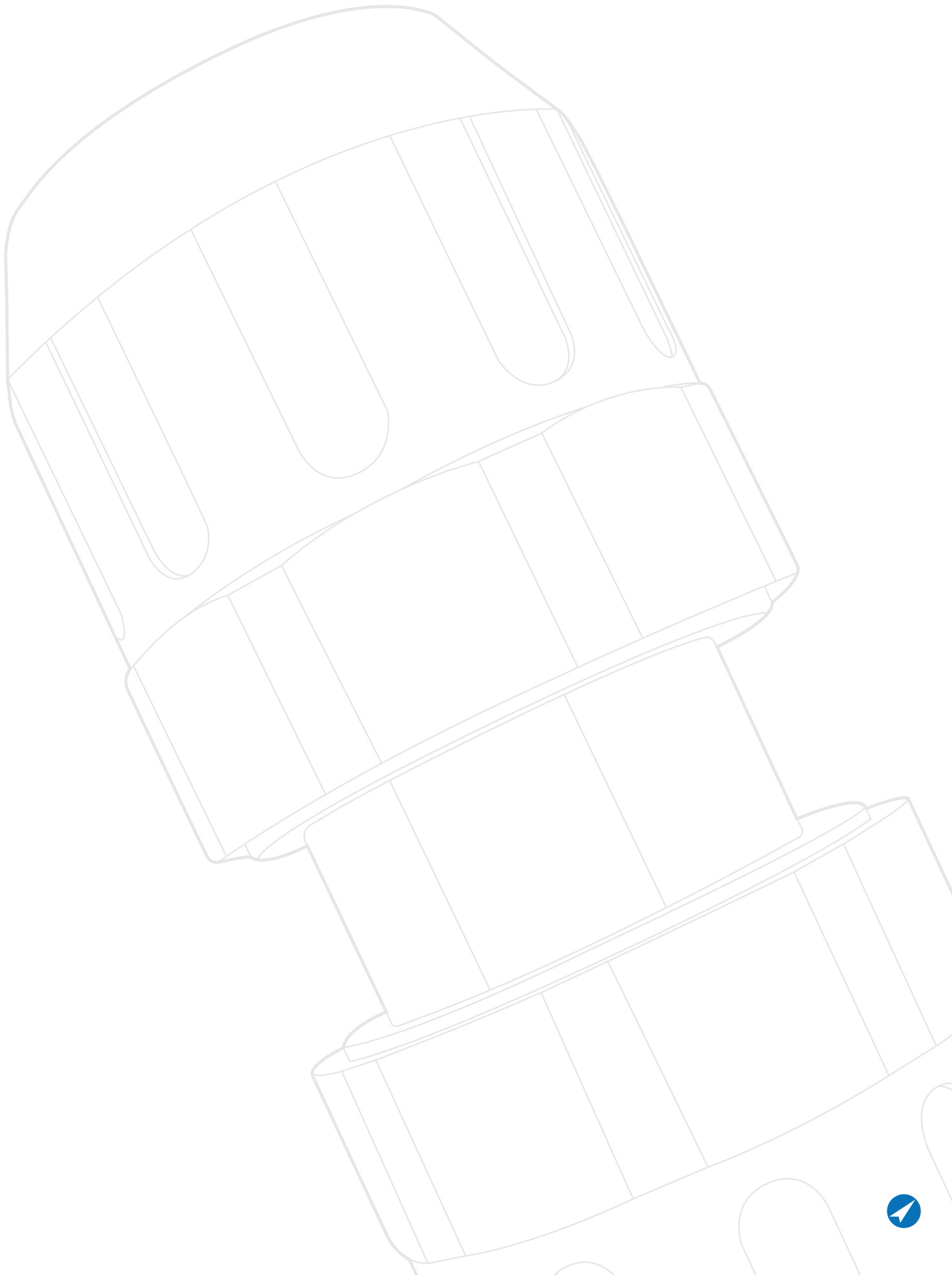



5°C ÷ +60°C

Max. Working pressure:  
10 Bar

Compressed air

Filter pressure reducers and lubricators combine the functions of a filter, a pressure reducer and a lubricator in a single unit.

The special shape of the bowl protection allows to see the oil level in the lubricator.

The flow of the circulating oil can be observed from the see-trough window and can be regulated by the special adjustment screw.

Body: Aluminum  
Diaphragm: NBR  
Spring: Zinc-plated steel  
Handle: Charged nylon  
Ring nut: Plastic (FPFRPLP02 and FPFRLGPL02)  
Aluminum (FPFRMLM04 and FPFRLGLM04)  
Seal: NBR  
Shutter: Brass - NBR  
TBowl: Polycarbonate (FPFRPLP02 and FPFRLGPL02)  
Polycarbonate with steel protection (FPFRMLM04 and FPFRLGLM04)  
Drain mode: Brass and ABS  
Whirlpool element: ABS  
Filter: Sinterized bronze  
Oil filler cap: ABS  
Oil screw adjustment: Brass and ABS  
Venturi's device: Polyurethane  
Venturi element support: Polyurethane



Prodotti conformi al regolamento CE 1907/2006



Prodotti conformi alla direttiva EU 2015/863

CODE	NOMINAL FLOW RATE *	ADJUSTMENT RANGE	FILTER DEGREE	BLOW CAPACITY	MIN. FLOW OF OIL DROP
FPFRPLP02 FPFRGPLP02	500 NI/min	0,5 - 8,5 Bar	25 µm	25 cm <sup>3</sup>	15 NI/min
FPFRMLM04 FPFRGLM04	3000 NI/min	0,5 - 8,5 Bar	25 µm	130 cm <sup>3</sup>	50 NI/min

\* Flow rate measured with an inlet pressure of 7 bar and an outlet pressure of 5 bar

**FLOW CHART**  
**FPFRPLP02 / FPFRLGPL02**

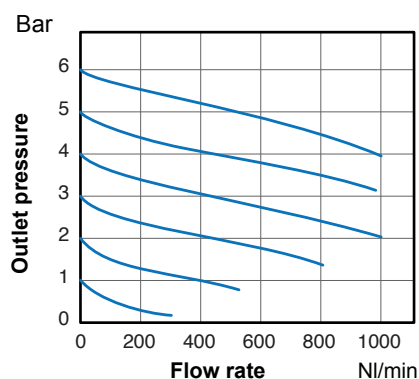

**FLOW CHART**  
**FPFRMLM04 / FPFRLGLM04**

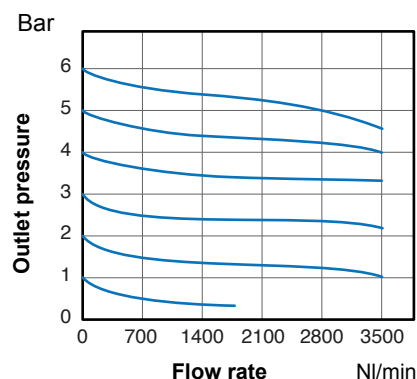

**FPFR-L**

Filter, pressure regulator and lubricator

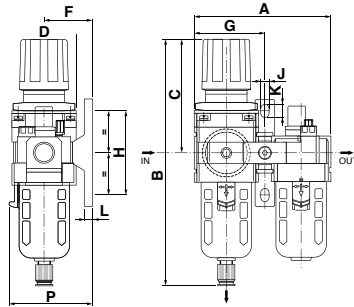

\* Pressure regulators with the possibility of adding a pressure gauge.  
 For FPFRPLP02 code: MABP40R0138 pressure gauge (pressure gauge data sheet supplied on request)

CODE *	THREAD	A	B	C	D	F	G	H	J	K	L	P	WEIGHT (g)
FPFRPLP02	G 1/4"	90	150	78	40	30	45	48	5,5	8,5	5	50	660

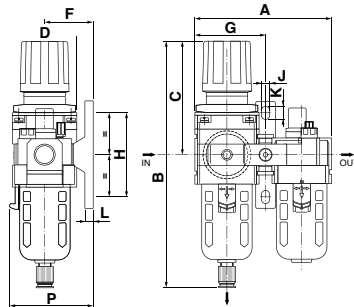

\* Pressure regulators with the possibility of adding a pressure gauge.  
 For FPFRMLM04 code: MABP50R0238 pressure gauge (pressure gauge data sheet supplied on request)

CODE *	THREAD	A	B	C	D	F	G	H	J	K	L	P	WEIGHT (g)
FPFRMLM04	G 1/2"	154	262	112	70	50	77	80	9	13	7	88	1930

**FPFRG-L**

Filter, pressure regulator and lubricator with integrated pressure gauge

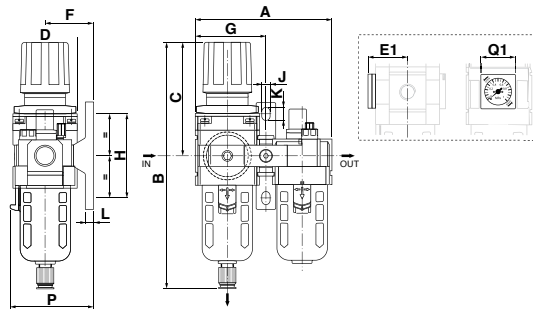

CODE	THREAD	A	B	C	D	E1	F	G	H	J	K	L	P	Q1	WEIGHT (g)
FPFRGPLP02	G 1/4"	90	150	78	40	29	30	45	48	5,5	8,5	5	50	27	680

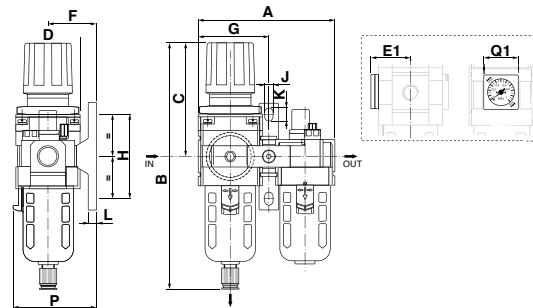

CODE	THREAD	A	B	C	D	E1	F	G	H	J	K	L	P	Q1	WEIGHT (g)
FPFRMLM04	G 1/2"	154	262	112	70	31	50	77	80	9	13	7	88	27	1940



## FPSTRP

L bracket

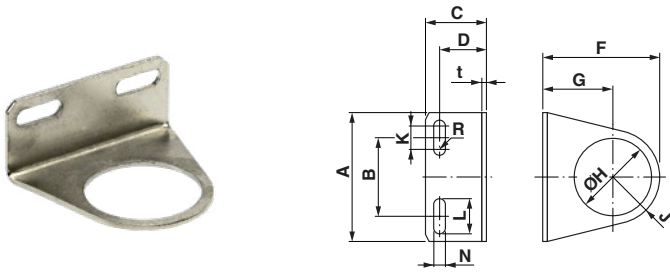

L bracket to use with the following series:  
 FPRP, FPRPG, FPFPR, PFPRM, FPFPRPG and FPFPRMG

CODE	A	B	C	D	F	G	ØH	J	K	L	N	R	t	WEIGHT (g)
FPSTRP02	55	34	25	19	50	30	33,5	20	10	15,4	5,4	2,7	2	35
FPSTRP04	70	54	27	18	79,2	49,2	52,5	30	2	10,5	8,5	4,25	2	60

## FPSTFL

L bracket

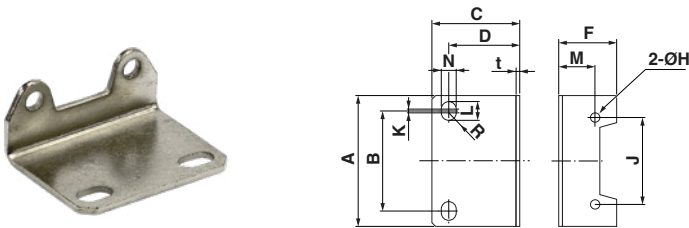

L bracket to use with the following series::  
 FPFPR, FPFPRM, FPLP and FPLM

CODE	A	B	C	D	F	ØH	J	K	L	M	N	R	t	WEIGHT (g)
FPSTFL02	40	27	33	27	18	4,5	26	3	8,4	14	5,4	2,7	2	24
FPSTFL04	70	54	47	38	31	5,5	47	2	10,5	20	8,5	4,25	2	67

## FPST

Full T bracket

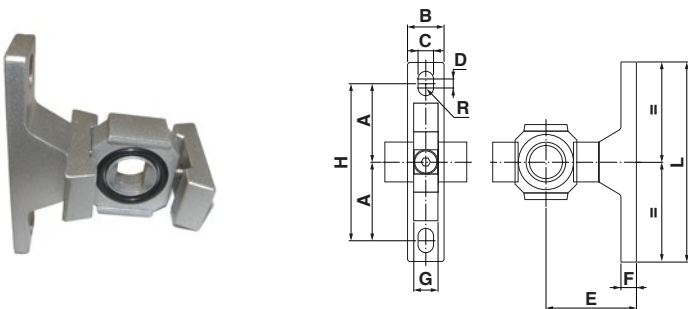

CODE	A	B	C	D	E	F	G	H	L	R	WEIGHT (g)
FPST02	24	15	5,5	3	30	5	10	48	66	2,75	77
FPST04	40	22	9	4	50	7	14	80	100	4,5	137



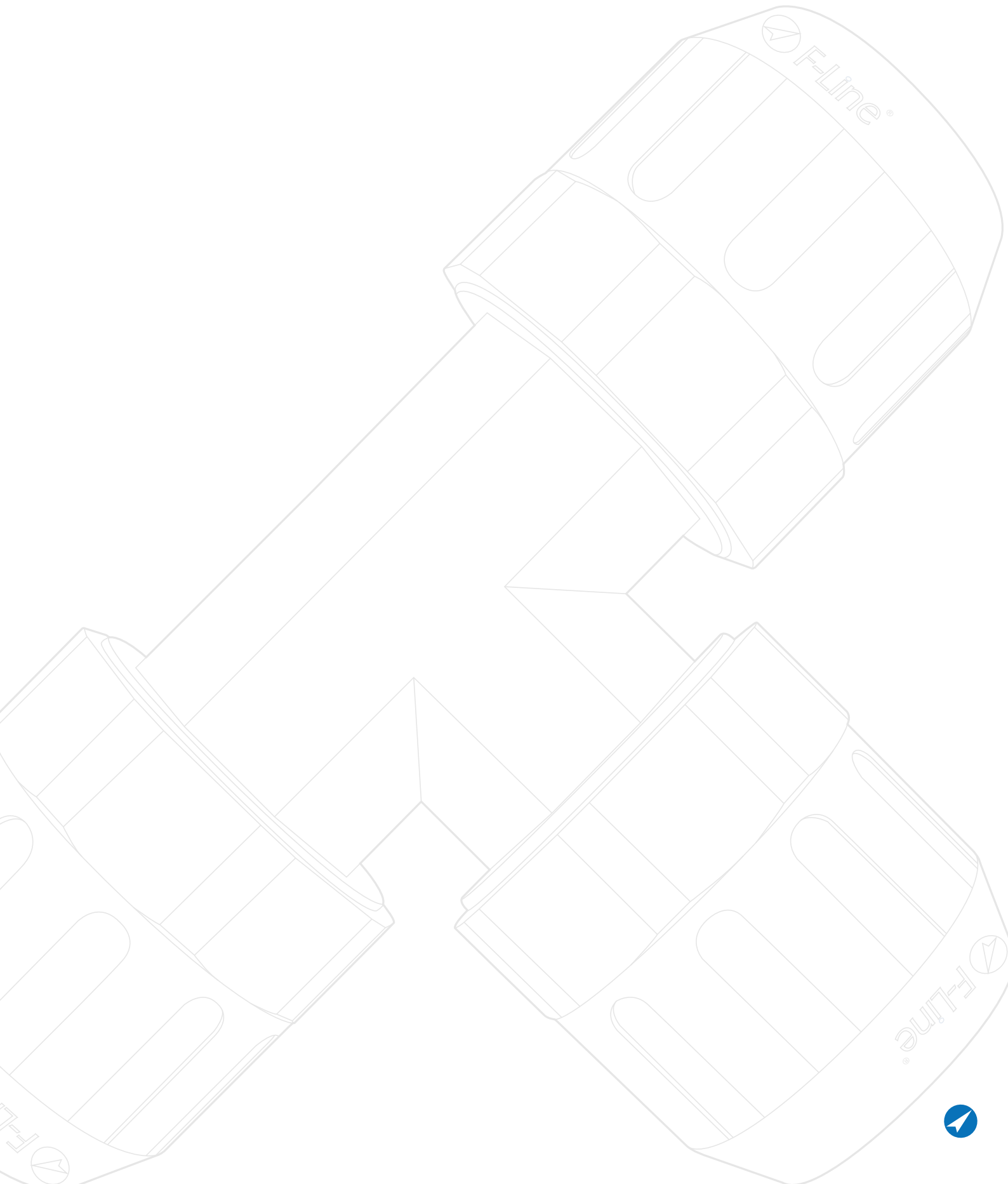





 -15°C ÷ +80°C

 Working pressure:  
16 Bar

 Compressed air

 - Taper gas BSPT ISO 7  
from R1/4" to R1/2"  
- Parallel gas BSPP ISO 228  
from G1/4" to G1/2"

 Body: Nickel-plated brass  
with 6 stainless steel spheres

### PROFILE - UNIVERSAL SERIES

The 8400 Series multi-socket allows 4 different profiles to be used while managing a single quick coupling. A simple solution for handling profiles that are not compatible with each other.

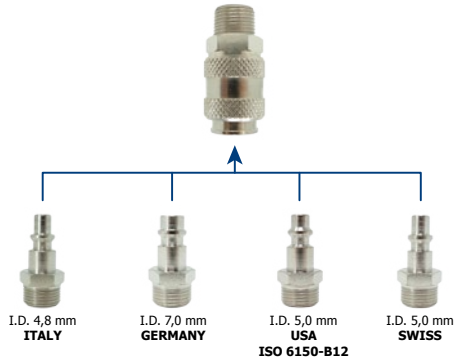

 Products in compliance with EC Regulation 1907/2006

 Products in compliance with the directive EU 2015/863

### AIR FLOWRATE UNIVERSAL SERIES

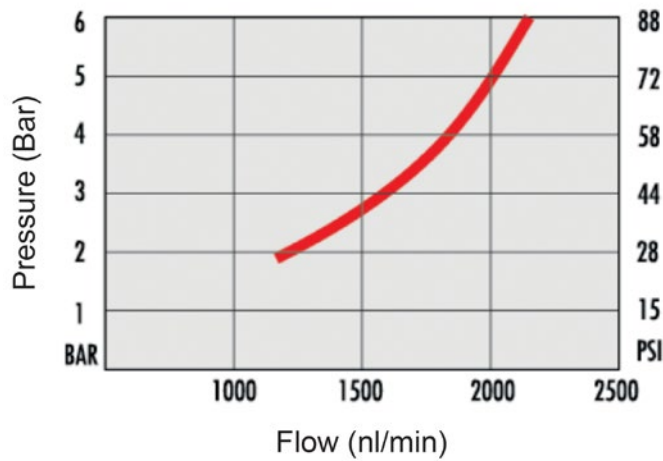

### 8410

### Male quick coupling BSPT thread

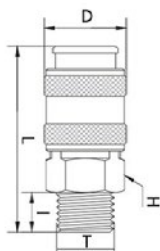

CODE	T	I	D	L	H
8410PRO02	R 1/4"	11	24,0	58	20
8410PRO03	R 3/8"	11,5	24,0	54	20
8410PRO04	R 1/2"	14	24,0	56,5	22

## 8420

### Female quick coupling BSPP thread

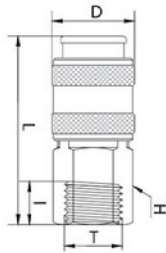

CODE	T	I	D	L	H
8420PRO02	G 1/4"	11	24	55	20
8420PRO03	G 3/8"	12	24	55	20
8420PRO04	G 1/2"	14	28	55	25

## 8430

### Quick coupling with barb connector

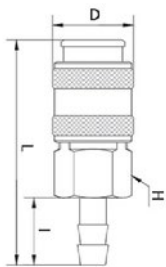

CODE	INT. TUBE Ø	I	BARB	D	L	H
8430PRO06	6	20	6,5	24,0	67	20
8430PRO08	8	20	9	24,0	67	20
8430PRO10	10	20	11,5	24,0	67	20
8430PRO12	12	24	13,5	24,0	71	20

## 8440

### Quick coupling with hose connector

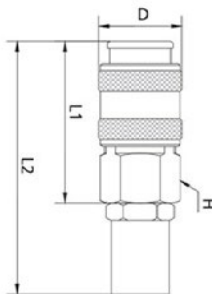

CODE	Ø	D	L1	L2	H
8440PRO610	6x10	24	47	73	20
8440PRO612	6x12	24	47	73	20
8440PRO614	6x14	24	47	73,5	20
8440PRO812	8x12	24	47	73	20
8440PRO814	8x14	24	47	73,5	20
8440PRO817	8x17	24	47	73,5	20
8440PRO10145	10x14,5	24	47	73,5	20
8440PRO1017	10x17	24	47	73,5	20
8440PRO1019	10x19	24	47	77	20

## 8450

### Quick coupling with push-on connector and spring

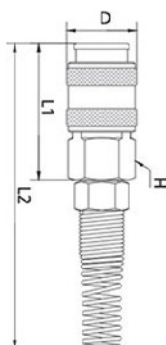

CODE	Ø	D	L1	L2	H
8450PRO58	5x8	24	47	148	20
8450PRO68	6x8	24	47	148	20
8450PRO6510	6,5x10	24	47	148	20
8450PRO810	8x10	24	47	148	20
8450PRO812	8x12	24	38	155	20
8450PRO1012	10x12	24	38	155	20





 -20°C ÷ +100°C

 Working pressure:  
From 0 to 12 Bar

 DN 7,4 mm

 Compressed air

 - Taper gas BSPT ISO 7  
from R1/8" to R1/2"  
- Parallel gas BSPP ISO 228  
from G1/8" to G1/2"

Body: Nickel-plated brass

Button: Zinc-plated steel

Connection: Aluminium

Seal: NBR

Plug connection: Zinc-plated steel

### CONFIGURATIONS

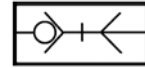

SO  
Single  
Shutter

### PROFILE

EUROSTANDARD  
GERMANY PROFILE

### FEATURES

- FPGS series are only to be used with FPIN series.
- **Safety** 2-stage quick couplings.

 Products in compliance with  
EC Regulation 1907/2006



 Products in compliance with  
the directive EU 2015/863

### AIR FLOW RATE BUTTON QUICK COUPLINGS

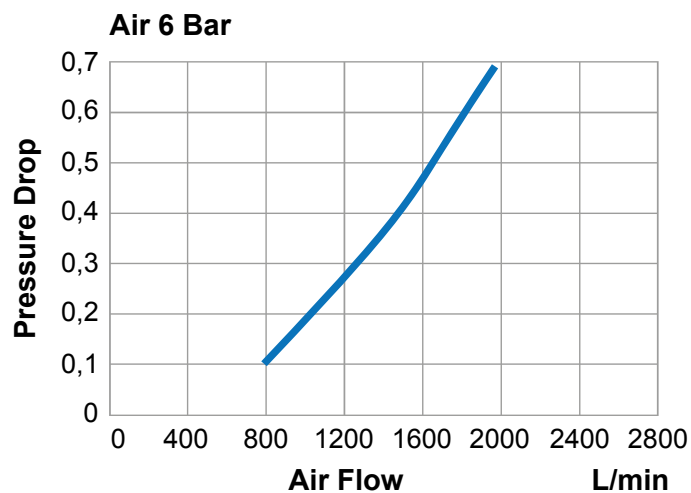

## FPGSM

### Safety male button quick coupling BSPT thread

SAFETY

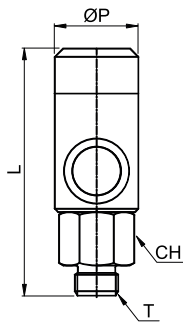

CODE	T	ØP	L	CH	WEIGHT (g)
FPGSM25R02	R 1/4"	26	69	20	110
FPGSM25R03	R 3/8"	26	68	20	128
FPGSM25R04	R 1/2"	26	70	25	142

## FPGSF

### Safety female button quick coupling BSPP thread

SAFETY

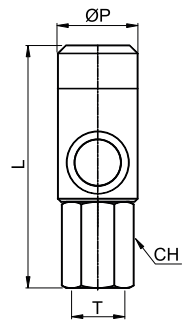

CODE	T	ØP	L	CH	WEIGHT (g)
FPGSF25G02	G 1/4"	26	68	20	136
FPGSF25G03	G 3/8"	26	72	20	133
FPGSF25G04	G 1/2"	26	74	25	168

## FPGSB

### Safety button quick coupling with barb connector

SAFETY

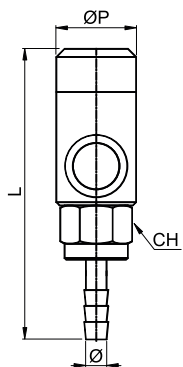

CODE	INT. TUBE Ø	ØP	BARB	L	CH	WEIGHT (g)
FPGSB25D06	6	26	7,3	83,5	20	138,5
FPGSB25D08	8	26	9,4	83,5	20	126
FPGSB25D10	10	26	11,3	83,5	20	115,5



**FPINM**

Male connection BSPT thread

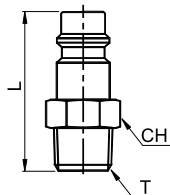

CODE	T	L	CH	WEIGHT (g)
FPINM25R01	R 1/8"	33	16	19
FPINM25R02	R 1/4"	37	14	22
FPINM25R03	R 3/8"	37	17	25
FPINM25R04	R 1/2"	43	22	48

**FPINF**

Female connection BSPP thread

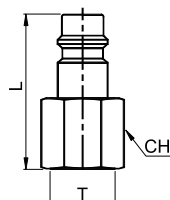

CODE	T	L	CH	WEIGHT (g)
FPIINF25G01	G 1/8"	32	14	20
FPIINF25G02	G 1/4"	33	17	25
FPIINF25G03	G 3/8"	33	19	26
FPIINF25G04	G 1/2"	36	24	41

**FPINB**

Connection with barb connector

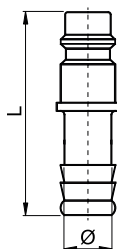

CODE	INT. TUBE Ø	BARB	L	WEIGHT (g)
FPINB25D06	6	7,3	46	15
FPINB25D08	8	9,3	46	16
FPINB25D10	10	11,3	48	18,5



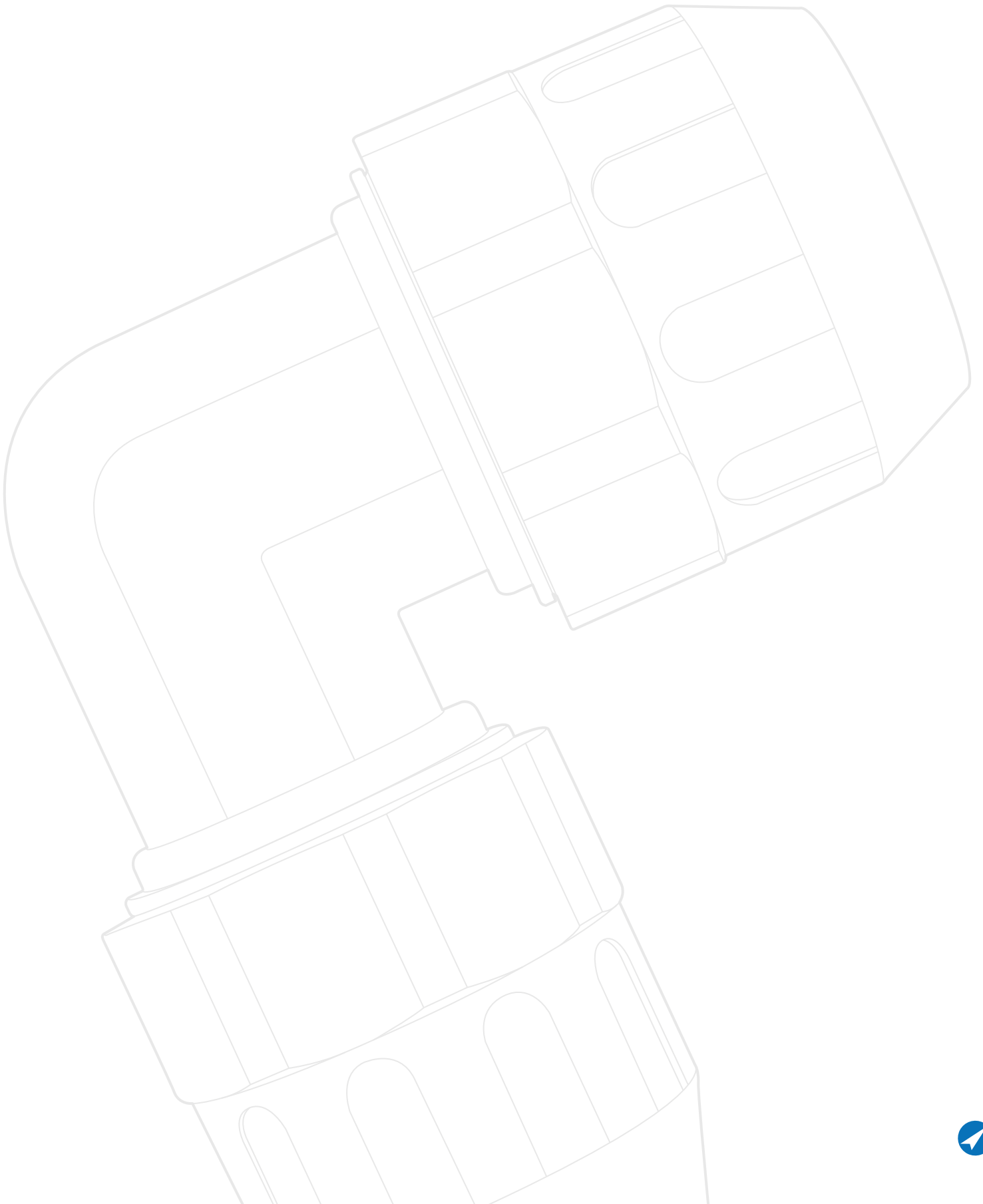





 -18°C ÷ +80°C

 Working pressure:  
12 Bar

 Compressed air

 Parallel gas BSPP ISO 228  
from G1/4" to G1/2"

 Body: Nickel-plated brass  
Spring: Nickel-plated steel

**PROFILE - JAPAN SERIES**



**NOMINAL DIAMETER**

7,5 mm

**AIR FLOWRATE**

2000 l/min



Products in compliance with  
EC Regulation 1907/2006



Products in compliance with  
the directive EU 2015/863

**VIEW - QUICK COUPLING 8910**

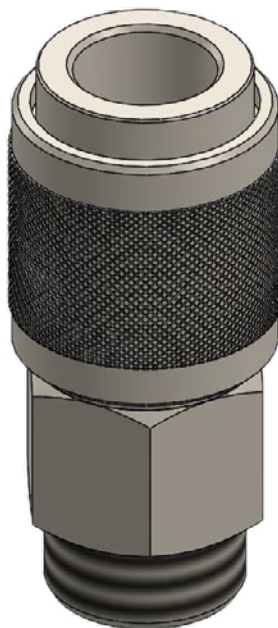

## 8910

### Male quick coupling BSPP thread

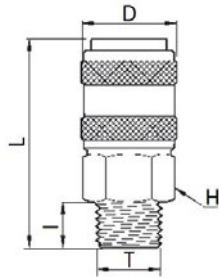

CODE	T	I	D	L	H
8910PRO02	G 1/4"	11,0	24,0	56,5	20
8910PRO03	G 3/8"	11,5	24,0	53,0	20
8910PRO04	G 1/2"	14,0	24,0	55,0	22

## 8920

### Female quick coupling BSPP thread

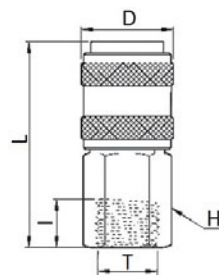

CODE	T	I	D	L	H
8920PRO02	G 1/4"	11,0	24,0	54,0	20
8920PRO03	G 3/8"	12,0	24,0	54,0	20
8920PRO04	G 1/2"	14,0	24,0	55,0	20

## 8930

### Quick coupling with barb connector

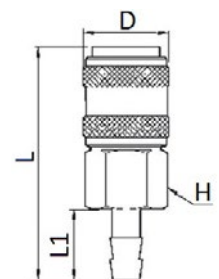

CODE	INT. TUBE Ø	D	L1	L	H
8930PRO08	8	24,0	20,0	67,0	19
8930PRO10	10	24,0	20,0	67,0	19
8930PRO12	12	24,0	20,0	67,0	19



## 8960

## Male connection BSPP thread

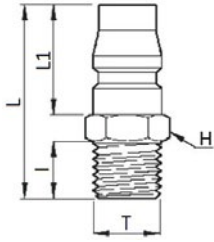

CODE	T	I	L	L1	H
8960PRO02	G 1/4"	11,0	37,0	21,0	14
8960PRO03	G 3/8"	11,5	37,5	21,0	17
8960PRO04	G 1/2"	14,0	40,5	21,0	22

## 8970

## Female connection BSPP thread

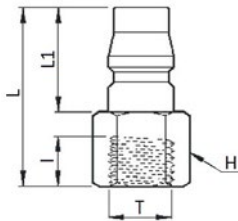

CODE	T	I	L	L1	H
8970PRO02	G 1/4"	12,0	36,0	21,0	17
8970PRO03	G 3/8"	13,0	37,0	21,0	19
8970PRO04	G 1/2"	14,0	38,0	21,0	22

## 8980

## Connection with barb connector

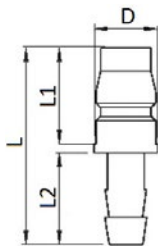

CODE	INT. TUBE Ø	D	L	L1	L2
8980PRO06	6	20	43,0	14,0	21,0
8980PRO08	8	20	43,0	14,0	21,0
8980PRO10	10	20	43,0	14,0	21,0



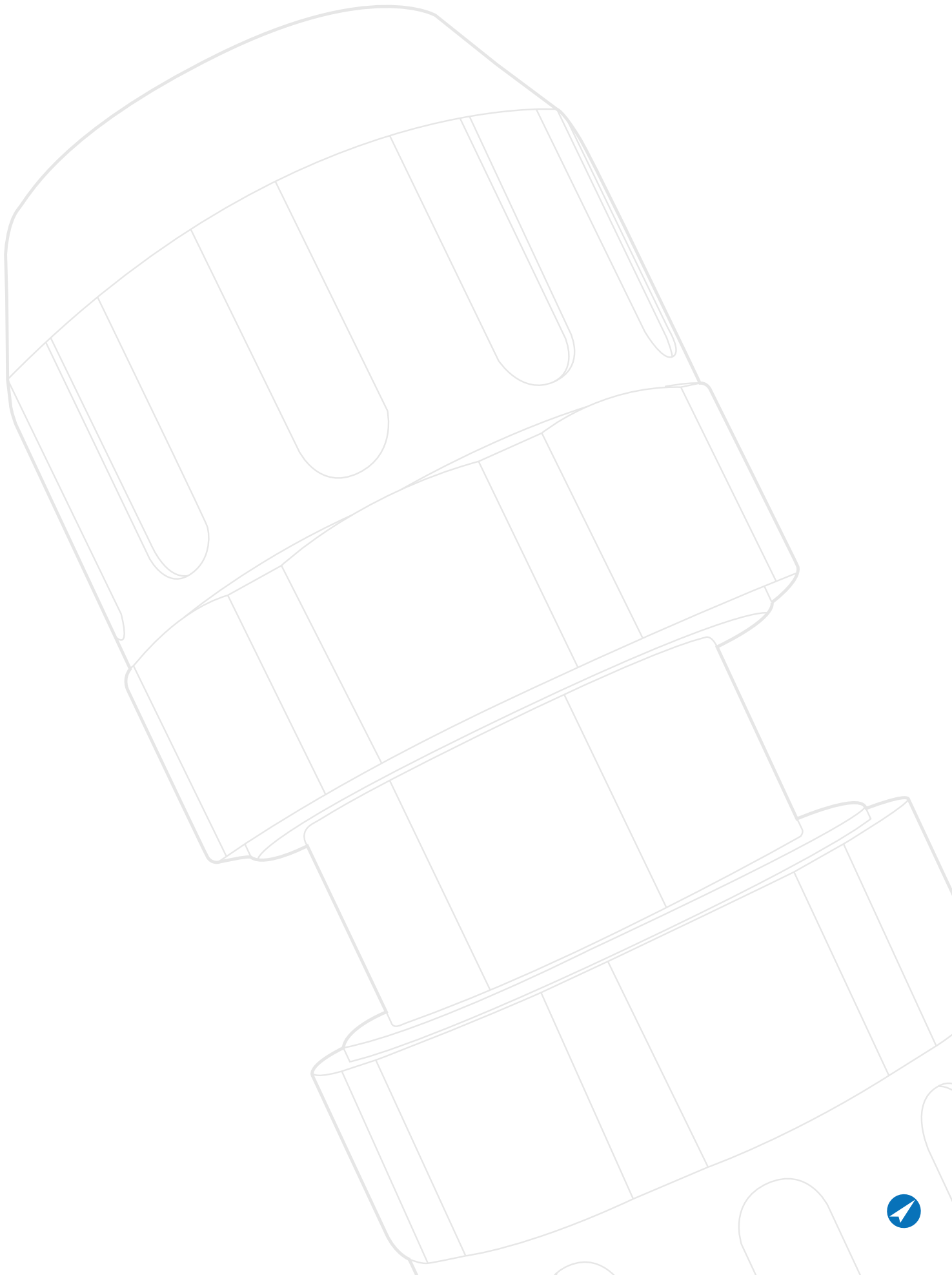



-20°C ÷ +60°C



Working pressure:

20 Bar

Bursting pressure:

60 Bar



Compressed air, vacuum  
and fluids suitable with the  
construction materials



Inner layer: Transparent PVC in a  
special blend

Reinforcement: Synthetic textile insert

Outer layer: PVC with polyurethane

**SILICONE FREE**



Products in compliance with  
EC Regulation 1907/2006

**RoHS3**

Products in compliance with  
the directive EU 2015/863

## PU-PVC

Light blue polyurethane tube with non-toxic PVC inner layer



CODE	Ø IDxOD	THICKNESS (mm)	MIN. BENDING RADIUS (mm)	WORKING PRESSURE (Bar)	BURSTING PRESSURE (Bar)	g/m	Q.TY FOR ROLL (mt)
PU-PVCPRO0610AZ	6x10	2	55	20	60	65	100
PU-PVCPRO0812AZ	8x12	2	65	20	60	80	100
PU-PVCPRO1015AZ	10x15	2,5	68	20	60	100	100
PU-PVCPRO1016AZ	10x16	3	70	20	60	155	100
PU-PVCPRO1319AZ	13x19	3	105	20	60	180	100



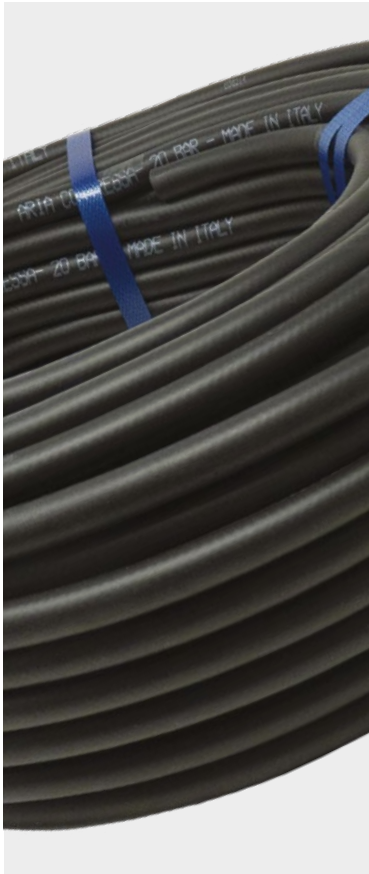

-20°C ÷ +60°C



Working pressure:

20 Bar

Bursting pressure:

60 Bar



Compressed air, vacuum and fluids suitable with the construction materials



Inner layer: PVC in a special blend

Reinforcement: Synthetic polyester textile insert

Outer layer: PVC

**SILICONE FREE**



Products in compliance with EC Regulation 1907/2006



Products in compliance with the directive EU 2015/863

## PVC-AC

Black PVC tube with reinforcement in polyester fiber



CODE	Ø IDxOD	THICKNESS (mm)	MIN. BENDING RADIUS (mm)	WORKING PRESSURE (Bar)	BURSTING PRESSURE (Bar)	g/m	Q.TY FOR ROLL (mt)
PVC-ACPRO0614NE100	6x14	4	25	20	60	170	100
PVC-ACPRO0817NE100	8x17	4,5	30	20	60	240	100
PVC-ACPRO1019NE100	10x19	4,5	32	20	60	280	100
PVC-ACPRO1323NE	13x23	5	40	20	60	390	50
PVC-ACPRO1928NE	19x28	4,5	60	20	60	550	50





-5°C ÷ 50°C



Max. Working pressure:  
15 Bar



Compressed air



Parallel gas BSPP ISO 228  
G 1/4" and G 3/8"



Tube: Polyurethane PU with  
high tenacity polyester yarn  
reinforcement  
Fittings: Brass

## PLUS

- Automatic spring rewind
- Swivelling metal fixing bracket
- Controlled tube rewinding for improved safety
- System for locking the tube to the desired length
- Internal mechanism to prevent jamming during hose drafting and rewinding



Products in compliance with  
EC Regulation 1907/2006



Products in compliance with  
the directive EU 2015/863

## FPAV

## Automatic hose reel



CODE	Ø IDxOD	TUBE THICKNESS (mm)	TUBE LENGTH (m)	INLET THREAD	OUTLET THREAD (MALE)	SIZES (cm)	WEIGHT (kg)
FPAV120816G14	8x12	2	15+1	-	G 1/4"	49x38x21	8
FPAV141016G38	10x14	2	15+1	-	G 3/8"	49x38x21	8

Fixing holes Ø: Ø6mm

Distance between the two fixing holes: 160mm



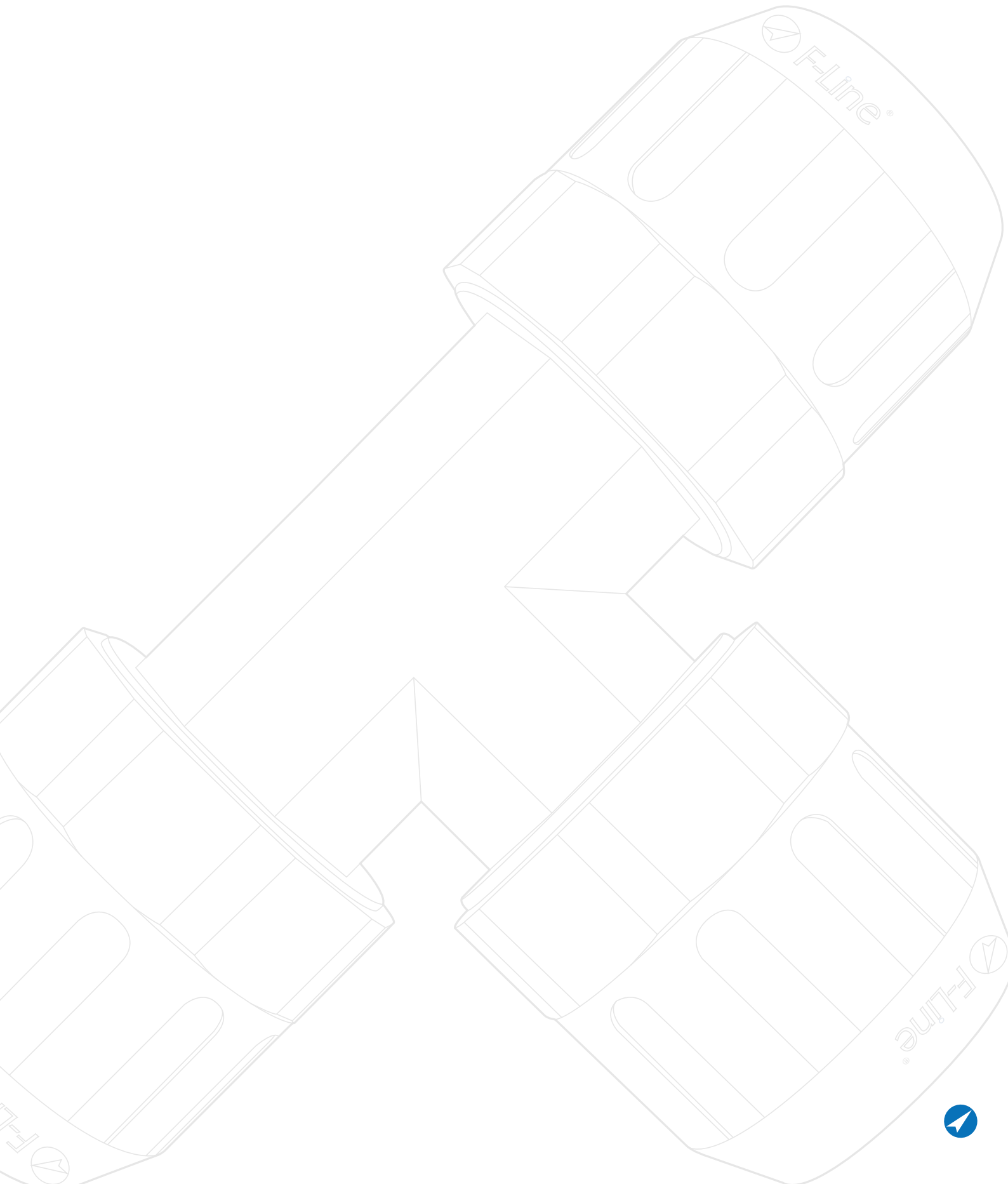

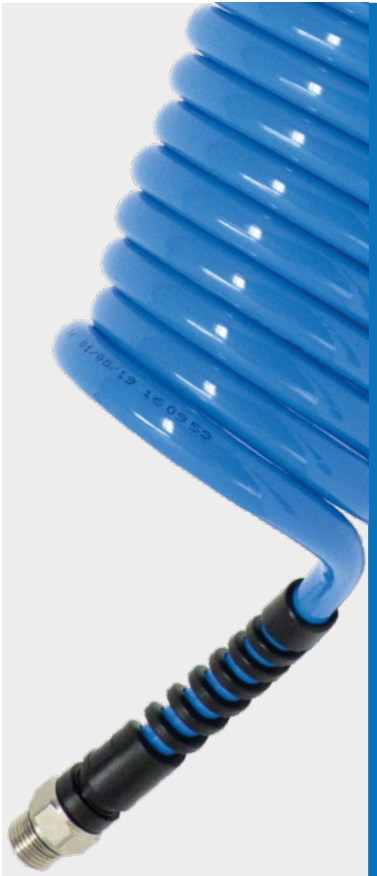

-40°C ÷ +60°C



**Working Pressure:**

See the table

**Negative Pressure:**

-0,95 Bar ( - 95 kPa)



Compressed air



Parallel gas BSPP ISO 228  
G 1/4" and G 3/8"



**Tube:** Polyurethane on polyester  
basis

**Fittings:** Nickel-plated brass

## FEATURES

Very flexible tubing with good elastic properties even at low temperatures. Good chemical, abrasion and ageing resistance. If exposed to sunlight, color may change slightly but mechanical features remain unchanged.

**Hardness:** Shore 98 A

**Ultimate tensile strength:** 50 MPa

**Ultimate tensile strain:** 400%

**Specific weight:** 1,23 g/cc

**Ultimate shear strength:** 123 N/mm

**Abrasion resistance:** 30 mm<sup>3</sup>



Products in compliance with  
EC Regulation 1907/2006



Products in compliance with  
the directive EU 2015/863

## WORKING PRESSURE EXPRESSED IN % AS A FUNCTION OF TEMPERATURES

20°C	30°C	40°C	50°C	60°C
100%	83%	72%	64%	47%



**UCES-G**

PU coiled tube on polyester basis with spring & BSPP thread fittings

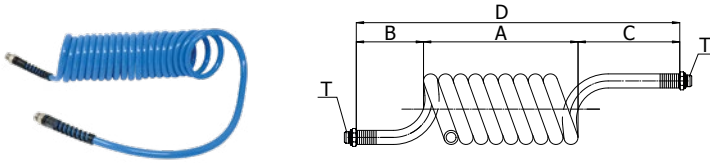

CODE	Ø ODxID	T	A (mm)	B (mm)	C (mm)	D (mm)	WORKING PRESSURE AT 23 °C (Bar)	BURSTING PRESSURE AT 23 °C (Bar)	LENGHT TUBE (m)	NUMBER OF TURNS	Ø INTERNAL COILED TUBE (mm)	WEIGHT (g)
* UCESPRO060435G14	6x4	2x G 1/4"	134	100	500	734	12	40	3,5	31	30	165
* UCESPRO060405G14		2x G 1/4"	266	100	500	866	12	40	5,0	44	30	190
* UCESPRO060475G14		2x G 1/4"	399	100	500	999	12	40	7,5	66	30	240
* UCESPRO060410G14		2x G 1/4"	532	100	500	1132	12	40	10,0	88	30	290
UCESPRO080535G14	8x5	2x G 1/4"	194	100	500	794	14	45	3,5	34	25	230
UCESPRO080505G14		2x G 1/4"	387	100	500	987	14	45	5,0	48	25	280
UCESPRO080575G14		2x G 1/4"	580	100	500	1180	14	45	7,5	72	25	375
UCESPRO080510G14		2x G 1/4"	773	100	500	1373	14	45	10,0	97	25	470
UCESPRO106505G14	10x6,5	2x G 1/4"	399	100	500	999	13	42	5,0	40	30	385
UCESPRO106575G14		2x G 1/4"	598	100	500	1198	13	42	7,5	60	30	525
UCESPRO106510G14		2x G 1/4"	797	100	500	1397	13	42	10,0	80	30	670
UCESPRO120805G38	12x8	2x G 3/8"	266	100	500	866	12	40	5,0	22	60	550
UCESPRO120875G38		2x G 3/8"	399	100	500	999	12	40	7,5	33	60	755
UCESPRO120810G38		2x G 3/8"	532	100	500	1132	12	40	10,0	44	60	955

\* Ø 6x4 fittings are in yellow brass

Sizes Ø ODxID	Light blue
6x4	UCESPRO060435G14AZ
	UCESPRO060405G14AZ
	UCESPRO060475G14AZ
	UCESPRO060410G14AZ
8x5	UCESPRO080535G14AZ
	UCESPRO080505G14AZ
	UCESPRO080575G14AZ
	UCESPRO080510G14AZ
10x6,5	UCESPRO106505G14AZ
	UCESPRO106575G14AZ
	UCESPRO106510G14AZ
12x8	UCESPRO120805G38AZ
	UCESPRO120875G38AZ
	UCESPRO120810G38AZ



**PED DECLARATION**

\* Declaration available on our website ([www.f-linepro.it](http://www.f-linepro.it)) or on request.



Tierre Group S.p.a.  
Sede: Via Dell'Industria 18 – 20032 Cormano (MI) – Italia  
Magazzino: Via Dell'Artigianato 2 – 20032 Cormano (MI) – Italia  
Produzione: Via Marco Biagi 1 – 25045 Castegnato (BS) – Italia  
C.F. e P.IVA IT 12437570158 – Cap. Soc. €2.000.000,00 i.v.  
REA MI-1558390

Tel. +39 02 663088.1 – Fax +39 02 66304172  
[www.tierregroup.com](http://www.tierregroup.com) – [info@tierregroup.com](mailto:info@tierregroup.com)

**DECLARATION OF CONFORMITY****PED****Pressure Equipment**

In accordance with Directive 2014/68/EU (PED) of the European Parliament and of the Council of 15 May 2014, as updated by Commission Implementing Decision (EU) 2025/165

**TIERRE GROUP S.p.A.**

**DECLARES**

that the products of the F-Line.PRO series, with diameters of 16mm, 20mm, 25mm, 40mm and 63mm, with a maximum PN of 16 bar, are classified in the category provided for in Article 4, paragraph 3.

These products are designed and manufactured in accordance with sound engineering practice and are not required to bear the CE marking, as specified in Article 18 of the same Directive.

Cormano, 30 gennaio 2025

TIERRE GROUP S.p.a.  
Dott. Marco Regis

A handwritten signature in blue ink, appearing to read "M. Regis", written over the printed name "Dott. Marco Regis".





# ALPHANUMERIC INDEX

1110PRO12	60	9210PRO2	59
1110PRO34	60	9210PRO212	59
1112PRO1234	60	9210PRO25	58
1410PRO12	54	9210PRO34	59
1412PRO1234	54	9210PRO40	58
8410PRO02	78	9210PRO63	58
8410PRO03	78	9220PRO1	59
8410PRO04	78	9220PRO112	59
8420PRO02	79	9220PRO12	59
8420PRO03	79	9220PRO2	59
8420PRO04	79	9220PRO20G04	58
8430PRO06	79	9220PRO25G04	58
8430PRO08	79	9220PRO25G05	58
8430PRO10	79	9220PRO25G06	58
8430PRO12	79	9220PRO34	59
8440PRO10145	79	9220PRO40G08	58
8440PRO1017	79	9250PRO1	59
8440PRO1019	79	9250PRO12	59
8440PRO610	79	9250PRO34	59
8440PRO612	79	9320PRO12	55
8440PRO614	79	9611PRO14	59
8440PRO812	79	AEU-75E-PRO10-316	57
8440PRO814	79	AEU-75E-PRO12-316	57
8440PRO817	79	AEU-75H-PRO-G02-316	57
8450PRO1012	79	AEU-75H-PRO-G03-316	57
8450PRO58	79	AEU-75H-PRO-G04-316	57
8450PRO6510	79	AEU-75M-PRO-R02-316	57
8450PRO68	79	AEU-75M-PRO-R03-316	57
8450PRO810	79	AEU-75M-PRO-R04-316	57
8450PRO812	79	EU-75N-PRO-R04-316V	56
8910PRO02	85	FP1610TR12	60
8910PRO03	85	FP1610TR34	60
8910PRO04	85	FPAL1614-4AZ	32
8920PRO02	85	FPAL2017-4AZ	32
8920PRO03	85	FPAL2017-AZ	32
8920PRO04	85	FPAL2017-GR	33
8930PRO08	85	FPAL2017-VD	33
8930PRO10	85	FPAL2522-4AZ	32
8930PRO12	85	FPAL2522-AZ	32
8960PRO02	86	FPAL2522-GR	33
8960PRO03	86	FPAL2522-VD	33
8960PRO04	86	FPAL4036-4AZ	32
8970PRO02	86	FPAL4036-AZ	32
8970PRO03	86	FPAL4036-GR	33
8970PRO04	86	FPAL4036-VD	33
8980PRO06	86	FPAL6359-AZ	32
8980PRO08	86	FPAL6359-GR	33
8980PRO10	86	FPAL6359-VD	33
9120PRO14	59	FPAN60	35
9210PRO1	59	FPAN85	35
9210PRO112	59	FPAV120816G14	90
9210PRO12	59	FPAV141016G38	90



FPAX1614	52
FPBR2520	46
FPBR25G04	46
FPBR4020	46
FPBR4025	46
FPBR40G05	46
FPBR6325	46
FPBR63G04	46
FPC16G04	39
FPC20R04	44
FPC25R04	44
FPC25R05	44
FPC40R06	44
FPCA25R06	44
FPCA40R08	44
FPCA63R10	44
FPCCH63	61
FPCH20	61
FPCH25	61
FPCH40	61
FPCH63	61
FPCL25	34
FPCL40	34
FPCL63	34
FPCLG2025	34
FPCLG40	34
FPCLG63	34
FPDAS-G05G04	54
FPDST2032	34
FPDST4063	34
FPFD25	61
FPFD4063	61
FPFM04	65
FPFP02	65
FPFRM04	69
FPFRMG04	69
FPFRMGLM04	75
FPFRMLM04	75
FPFRP02	69
FPFRPG02	69
FPFRPGLP02	75
FPFRPLP02	75
FPG2520	44
FPG4025	44
FPG6340	44
FPGSB25D06	81
FPGSB25D08	81
FPGSB25D10	81
FPGSF25G02	81
FPGSF25G03	81
FPGSF25G04	81
FPGSM25R02	81

FPGSM25R03	81
FPGSM25R04	81
FPGT25G05	46
FPGT4025	45
FPGT40G06	46
FPGT6340	45
FPGT63G09	46
FPHBT	62
FPINB25D06	82
FPINB25D08	82
FPINB25D10	82
FPINF25G01	82
FPINF25G02	82
FPINF25G03	82
FPINF25G04	82
FPINM25R01	82
FPINM25R02	82
FPINM25R03	82
FPINM25R04	82
FPIS20	33
FPIS25	33
FPL16G04	39
FPLC16	40
FPLM04	71
FPLP02	71
FPMAN4-G06G04	49
FPMP280	35
FPMRS370	35
FPMRS545	35
FPMTM8	35
FPPF20	46
FPPF25	46
FPPF40	46
FPPF63	46
FPRP02	67
FPRP04	67
FPRPG02	67
FPRPG04	67
FPSA04	72
FPSAS-G04G04	54
FPST02	76
FPST04	76
FPST16	34
FPST20	34
FPST25	34
FPST40	34
FPST63	34
FPSTFL02	76
FPSTFL04	76
FPSTMAN06-48	50
FPSTRP02	76
FPSTRP04	76

FPTT1632	62
FPTT1663	62
FPTUC25G06	36
FPTUC40G08	36
FPTUC63G10	36
FPTUX25-1000	37
FPTUX25-2000	37
FPTUX40-1500	37
FPTUX40-3000	37
FPTUX63-1500	37
FPTUX63-3000	37
FPUC16	39
FPUC20	44
FPUC25	44
FPUC40	44
FPUC63	44
FPUL16	40
FPUL20	45
FPUL25	45
FPUL40	45
FPUL63	45
FPULH20	45
FPULH25	45
FPULH40	45
FPUS1650	62
FPUT16	40
FPUT20	45
FPUT25	45
FPUT40	45
FPUT63	45
FPWLM1-G04G04	48
FPWLM2-G04G04	48
FPWLM2-G05G04	48
LOXPRO1810	63
PU-PVCPRO0610AZ	88
PU-PVCPRO0812AZ	88
PU-PVCPRO1015AZ	88
PU-PVCPRO1016AZ	88
PU-PVCPRO1319AZ	88
PVC-ACPRO0614NE100	89
PVC-ACPRO0817NE100	89
PVC-ACPRO1019NE100	89
PVC-ACPRO1323NE	89
PVC-ACPRO1928NE	89
R-PTFEPRO190215	63
UCESPRO060405G14AZ	93
UCESPRO060410G14AZ	93
UCESPRO060435G14AZ	93
UCESPRO060475G14AZ	93
UCESPRO080505G14AZ	93
UCESPRO080510G14AZ	93
UCESPRO080535G14AZ	93

UCESPRO080575G14AZ	93
UCESPRO106505G14AZ	93
UCESPRO106510G14AZ	93
UCESPRO106575G14AZ	93
UCESPRO120805G38AZ	93
UCESPRO120810G38AZ	93
UCESPRO120875G38AZ	93
XVHRCPRO16G04	53





[www.f-linepro.it](http://www.f-linepro.it) [info@tierregroup.com](mailto:info@tierregroup.com)



**Tierre Group S.p.a.**

via dell'Industria, 18 - 20032 Cormano (MI)

Tel. +39 02 663088.1 - Fax +39 02 66304172

[www.tierregroup.com](http://www.tierregroup.com) - [info@tierregroup.com](mailto:info@tierregroup.com)

C.F. e P.IVA 12437570158

Cap. Soc. Euro 2.000.000,00 i.v. - REA MI-1558390

F-Line.PRO catalogue - Ed. 3.1 - 03/26